



The University of New Mexico Health Sciences Center
COLLEGE OF PHARMACY



:::VOLUME 12, LESSON 4:::

*Pharmaceutical Care in PET Imaging:
Emphasis on [¹⁸F]FDG Imaging*

Continuing Education for Nuclear Pharmacists and
Nuclear Medicine Professionals

By

Laura L. Boles Ponto, Ph.D., RPh., FAPhA
Associate Research Scientist
PET Imaging Center
University of Iowa Hospitals and Clinics
Adjunct Assistant Professor
Department of Radiology



The University of New Mexico Health Sciences Center College of Pharmacy is accredited by the Accreditation Council for Pharmacy Education as a provider of continuing pharmaceutical education. Universal Activity Number (UAN) 039-000-10-124-H04-P 4.0 Contact Hours or .4 CEUs. Release date: 12/18/2009 Expiration date: 12/18/2012 This is an Application based program

-- Intentionally left blank --

***Pharmaceutical Care in PET Imaging:
Emphasis on [¹⁸F]FDG Imaging***

By

Laura L. Boles Ponto, Ph.D., RPh., FAPhA

Editor, CENP

Jeffrey P. Norenberg, MS, PharmD, BCNP, FASHP, FAPhA
UNM College of Pharmacy

Editorial Board

Sam Augustine, R.P, PharmD, FAPhA
Stephen Dragotakes, RPh, BCNP, FAPhA
Richard Kowalsky, PharmD, BCNP, FAPhA
Neil Petry, RPh, MS, BCNP, FAPhA
James Ponto, MS, RPh, BCNP, FAPhA, FASHP
Tim Quinton, PharmD, MS, BCNP, FAPhA
S. Duann Vanderslice, RPh, BCNP, FAPhA

Advisory Board

Dave Abbott, RPh, BCNP
Fred Gattas, PharmD, BCNP
Mark Gurgone, BS, RPh.
Vivian Loveless, PharmD, BCNP, FAPhA
Lisa Marmon, RPh, BCNP
Michael Mosley, RPh, BCNP
Janet Robertson, BS, RPh, BCNP
Brantley Strickland, BCNP
John Yuen, PharmD, BCNP

Director, CENP

Kristina Wittstrom, RPh, BCNP
UNM College of Pharmacy

Administrator, CE & Web Publisher

Christina Muñoz, B.S.
UNM College of Pharmacy

While the advice and information in this publication are believed to be true and accurate at the time of press, the author(s), editors, or the publisher cannot accept any legal responsibility for any errors or omissions that may be made. The publisher makes no warranty, expressed or implied, with respect to the material contained herein.

Copyright 2006
University of New Mexico Health Sciences Center
Pharmacy Continuing Education
Albuquerque, New Mexico

PHARMACEUTICAL CARE IN PET IMAGING: EMPHASIS ON [¹⁸F]FDG IMAGING

STATEMENT OF OBJECTIVES

Upon completion of this course you will be able to:

1. To understand the current indications for PET radiopharmaceuticals, in general, and [¹⁸F]fludeoxyglucose (FDG), specifically.
2. To understand the pharmacology of [¹⁸F]fludeoxyglucose (FDG).
3. To understand the pharmacokinetics of [¹⁸F]fludeoxyglucose (FDG).
4. To understand the physiological processes that may alter the biodistribution of [¹⁸F]fludeoxyglucose (FDG).
5. To understand the important and potential drug interactions with [¹⁸F]fludeoxyglucose (FDG).
6. To understand the role that pharmacists may play in optimizing the utility of [¹⁸F]fludeoxyglucose (FDG) imaging.

COURSE OUTLINE

PHARMACEUTICAL CARE IN IMAGING.....	6
PHYSIOLOGICAL IMAGING AND PET RADIOPHARMACEUTICALS	7
CLINICAL IMPORTANCE OF FDG IN PET IMAGING.....	9
FDG PHARMACOLOGY	9
FDG INDICATIONS	9
MECHANISM OF ACTION	10
MECHANISM OF ACTION	11
DISTRIBUTION.....	12
RADIATION DOSIMETRY	14
PHARMACOKINETIC MODELING	15
COMPARTMENTAL AND NON-COMPARTMENTAL MODELING.....	15
STANDARDIZED UPTAKE VALUES (SUV)	16
IMPLICATIONS OF THE PHARMACOKINETIC MODEL	20
CLINICAL USE OF FDG.....	20
GENERAL CONSIDERATIONS	20
BRAIN IMAGING.....	24
CARDIAC IMAGING	27
ONCOLOGIC IMAGING	30
PHARMACEUTICAL CARE ISSUES IN FDG IMAGING	34
ADJUNCTIVE AGENTS.....	39
DRUG INTERACTIONS.....	41
PHARMACEUTICAL CARE ROLES	43
CONCLUSION	44
APPENDIX A.....	45
PHARMACOKINETIC MODELS FOR THE DETERMINATION OF THE METABOLIC RATE OF GLUCOSE FROM FDG IMAGES	45
QUESTIONS.....	53

PHARMACEUTICAL CARE IN PET IMAGING: EMPHASIS ON [¹⁸F]FDG IMAGING

By

Laura L. Boles Ponto, Ph.D., RPh., FAPhA
Associate Research Scientist
PET Imaging Center
University of Iowa Hospitals and Clinics
Adjunct Assistant Professor
Department of Radiology

PHARMACEUTICAL CARE IN IMAGING

In the more traditional sense, the practice of nuclear pharmacy and specifically, positron emission tomography (PET) imaging generally falls outside of the usual conceptualization of “pharmaceutical care”. However, under closer examination, pharmaceutical care concepts pertain to these areas of medicine/pharmacy just as well as the more conventional aspects of pharmacy practice. Specifically,

- Radiopharmaceuticals are drugs.
- “Pharmaceutical care” implies the appropriate use of drugs in order to maximize their utility and minimize any negative outcomes.

“Functional imaging” involves the interplay of physiology/pathology and pharmacology, therefore, there is a role for “pharmaceutical care”.

The nature of this role will depend on the practice environment of the particular pharmacist. The nuclear pharmacist’s role involves the pharmaceutical handling (e.g., proper preparation/compounding, appropriate storage), dispensing activities (e.g., delivery of the correct radiopharmaceutical to the correct patient at the correct time) as well as clinical aspects of radiopharmaceuticals (e.g., drug interactions, physiological modifiers). Nuclear pharmacists practicing in centralized nuclear pharmacies, obviously, have a role in the compounding and dispensing of radiopharmaceutical doses, but also have pharmaceutical care roles in their advisory capacity to the hospitals and clinics that they serve. The critical role of imaging in the diagnosis and therapeutic monitoring of disease mandates that hospital and community-based pharmacists understand the utility, the limitations and the mechanistic underpinnings of these procedures in order to optimize this aspect of their patient’s health care.

Although positron emission tomography (PET) has been available for nearly 30 years, the recognized clinical utility of PET has exploded within the last decade, predominantly on the basis of the imaging of [¹⁸F]fludeoxyglucose (known as [¹⁸F]fluorodeoxyglucose or FDG). It will be the purpose of this lesson to address the pharmaceutical care issues surrounding PET imaging of FDG. This lesson is directed primarily to the nuclear pharmacy audience, however, because of the prevalence and importance of the diseases for which FDG imaging is proving to be a valuable diagnostic tool, much of the information contained in this lesson has application to all practice settings. Figure 1 presents a series of practice-based scenarios specifically involving FDG imaging.

Pharmaceutical Care Roles	
Nuclear Pharmacist	<i>A woman is scheduled for an FDG study who is currently nursing an infant. What recommendations should be made to this woman to minimize any risk to her infant?</i>
Centralized Nuclear Pharmacist	<i>You are supplying FDG to a mobile unit. You are asked by the technologist operating the mobile unit about how the uptake phase should be handled. “We plan on injecting the FDG in the mobile PET unit. Can we have the patient walk back into the hospital for the uptake phase?”</i>
Hospital Pharmacist	<i>“Patient Jones is an inpatient receiving parenteral nutrition. He is now scheduled for a PET study. Can we continue his TPN? If not, when should we discontinue?”</i>
Community Pharmacist	<i>“Patient Smith, one of my patients in the diabetes care program, has a solitary pulmonary nodule observed on chest CT. He is now scheduled for a PET study. The PET Center nurse has told him that he has to have his blood glucose level between 60 – 120 mg/dL. Why?”</i>

Figure 1. Pharmaceutical care roles of various types of pharmacy practice.

Physiological Imaging and PET Radiopharmaceuticals

Positron emission tomography (PET) images physiological processes (i.e., function) rather than organ structure. Figure 2 presents examples of the power of imaging physiology rather than simply anatomy.

Physiological imaging is inherently

- “State-dependent”
- Influenced by both disease-based and non-disease-based processes
- Influenced by processes of interest as well as nuisance processes

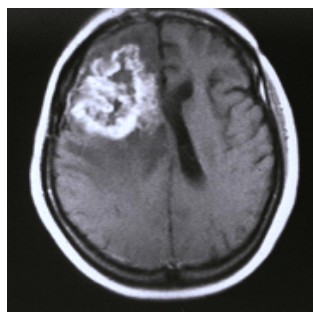

Anatomical Imaging
MRI with contrast

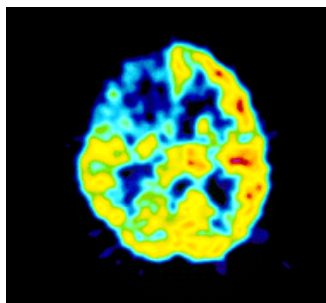
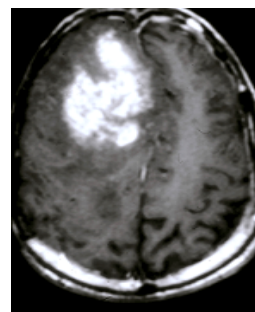

Functional Imaging
PET with FDG
(Glucose Analog)

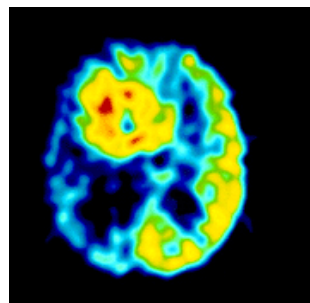

Figure 2. Brain images of two patients evaluated for possible recurrent brain tumor with contrast-enhanced MRI and FDG. Even though both patients had similar contrast enhancement on their MRI images, the FDG images tell very different stories. The patient on the left had a lack of metabolic activity in the area of the MRI abnormality, indicative of radiation necrosis, whereas the patient on the right had significant metabolic activity in the area of the MRI abnormality, indicative of recurrent tumor.

The nature of the physiological process imaged is dependent on the radiopharmaceutical utilized. Since positron-emitting radioisotopes of the major constituents of biomolecules (i.e., carbon ($[^{11}\text{C}]$), nitrogen ($[^{13}\text{N}]$), oxygen ($[^{15}\text{O}]$)) and drugs and analogues (i.e., fluorine ($[^{18}\text{F}]$)) exist, theoretically, any biological process could be imaged. However, the half-lives of the radionuclides (i.e., 2 to 110 minutes) pose limits on the duration of pharmaceutical compounding and quality assurance testing and the time-course of the biological processes that can be imaged, therefore, limiting the scope of practical PET radiopharmaceuticals. Even with these limitations,

PET Radiopharmaceuticals
[18F]Fluorodeoxyglucose (FDG) - glucose metabolism
[15O]Water - blood flow
[13N]Ammonia - perfusion
[11C]Methionine - amino acid metabolism
[11C]Choline/[18F]Fluorocholine - membrane metabolism
[11C]Flumazenil - benzodiazepine receptor mapping
[11C]Raclopride - dopamine D2 receptors mapping
[11C]Thymidine/[18F]Fluorothymidine - nucleic acid synthesis
[18F]Fluorodopa - presynaptic dopaminergic function
[82Rb]Rubidium – cardiac perfusion

Figure 3. Positron-emitting radiopharmaceuticals with documented utility

PET Radiopharmaceuticals with Special Legal Standing
<u>USP agents</u>
Ammonia N13
Fludeoxyglucose F18
Fluorodopa F18
Mespiperone C11
Methionine C11
Raclopride C11
Rubidium Rb82
Sodium acetate C11
Sodium fluoride F18
Water O15
<u>FDA agents</u>
Fludeoxyglucose F18
Ammonia N13
Rubidium Rb82

Figure 4. Positron-emitting radiopharmaceuticals recognized by the USP and FDA

numerous PET agents have been reported in the literature. Examples of agents with long-term utility for the listed physiological processes are presented in Figure 3 by their common names.

The agents with USP and USP-DI monographs are presented in Figure 4 by their official name.

Of these agents, only three have been recognized by the FDA. Rubidium Rb82 is a commercially-available, generator-produced PET radiopharmaceutical indicated for myocardial perfusion imaging (CardioGen-82®). Ammonia N13 and Fludeoxyglucose F18 have FDA- and CMS-approved indications, but only Fludeoxyglucose F18 has approved NDAs (i.e., New Drug Applications) at the present time.

Clinical Importance of FDG in PET Imaging

Fludeoxyglucose F18, also known as [¹⁸F]fluorodeoxyglucose or FDG is currently the most important PET radiopharmaceutical. The vast majority of clinical PET studies have been and will be carried out with FDG. The medical literature supports this level of use. For example, in 2005, the PubMed database had 3,486 hits for “positron emission tomography” of which 1,162 hits were for “FDG”. Because the half-life of [¹⁸F] is 109.8 minutes, commercial distribution of FDG is possible, making PET imaging available even at small hospitals and free-standing imaging centers throughout the United States. Research uses also constitute an important application of FDG PET as it is now becoming an integral part of Phase I – III trials of oncologic drugs primarily because of the recognition that functional changes frequently occur earlier in the time-course of response to a therapeutic intervention than anatomical or clinical changes.

FDG PHARMACOLOGY

FDG Indications

The USP-DI monograph for Fludeoxyglucose F18¹ lists indications for brain imaging, cardiac imaging and whole-body imaging based on the assessment of glucose metabolic patterns in the specified tissues for various physiological (e.g., viability) and pathological states (e.g., malignancy, infection). The primary reason for the widespread and growing use of FDG is the elegance of the mechanistically simple mode of action making this agent useful for imaging such diverse organ systems. Recognizing this utility, the Centers for Medicare and Medicaid Services (CMS) has approved FDG imaging for reimbursement in Medicare patients for a number of disorders and is seeking data to potentially expand further the oncologic indications through its National Oncologic Patient Registry (NOPR) program (www.cancerpetregistry.org) (see Figure 5).

CMS-approved Indications for FDG

Cardiac

Myocardial viability

Neurological

Refractory seizures – presurgical evaluation
Alzheimer’s disease – differential diagnosis of frontotemporal versus Alzheimer’s dementia

Oncology

(D = diagnosis, IS = initial staging, S = staging, RS = restaging, E = evaluation of therapy)

Lung cancer (non-small cell or single pulmonary nodule (SPN)) – D, IS, RS
Esophageal cancer – D, IS, RS
Colorectal cancer – D, IS, RS
Lymphoma – D, IS, RS
Melanoma – D, IS, RS
Head and neck cancers (excluding CNS and thyroid) – D, IS, RS
Breast cancer – S, E
Thyroid cancer (restricted) – RS
Cervix (restricted) – S

Indications Eligible for Entry in the NOPR

(D = diagnosis, S = staging, RS = restaging, M = monitoring of therapy)

Lip, oral cavity and pharynx – M
Esophagus – M
Stomach – D, S, RS, M
Small intestine – D, S, RS, M
Colon and rectum – M
Anus – D, S, RS, M
Liver and intrahepatic bile ducts – D, S, RS, M
Gallbladder and extrahepatic bile ducts – D, S, RS, M
Pancreas – D, S, RS, M
Retroperitoneum and peritoneum – D, S, RS, M
Nasal cavity, ear and sinuses – M
Larynx – D, S, RS, M
Lung, non-small cell – M
Lung, small cell – D, S, RS, M
Pleura – D, S, RS, M
Thymus, heart, mediastinum – D, S, RS, M
Bone/cartilage – D, S, RS, M
Connective/other soft tissue – D, S, RS, M
Melanoma of skin – M
Breast (male) – D, S, RS, M
Kaposi’s sarcoma – D, S, RS, M
Uterus – D, S, RS, M
Cervix – D, RS, M
Ovary – D, S, RS, M
Prostate – D, S, RS, M
Testis – D, S, RS, M
Penis and male genitalia – D, S, RS, M
Bladder – D, S, RS, M
Kidney and urinary tract – D, S, RS, M
Eye – D, S, RS, M
Brain (primary) – D, S, RS, M
Thyroid – D, S, M
Lymphoma – M
Myeloma – D, S, RS, M
Leukemia – D, S, RS, M
Lung, SPN – D
Other not specified – D, S, RS, M

Figure 5. Centers for Medicare and Medicaid Services (CMS) approved and National Oncology Patient Registry indications for FDG.

Mechanism of Action

Fludeoxyglucose F18 (FDG) is a glucose analogue, therefore, mechanistically, FDG imaging is based on the mapping of glucose metabolism. Chemically, [^{18}F] 2-fluoro-2-deoxyglucose (see Figure 6) is created by substituting a fluorine atom for the hydroxyl group located in the two position of the glucose ring structure.

Because of the similarity in size between a fluorine atom and a hydroxyl group, the resulting molecule is able to compete with glucose for active transport from blood to tissue and phosphorylation to the monophosphate (ie., glucose-6-P and FDG-6-P), the first two steps in glucose metabolism. Since FDG-6-P is not a substrate for further glycolytic pathways and has a membrane permeability that precludes the diffusion from the tissue to the blood, the tracer becomes entrapped within the tissues. The degree of entrapment is proportional to the rate of glycolysis or glucose metabolism of the tissue.

Because glucose is hydrophilic, entry into cells is not by simple diffusion. Transport of glucose, and therefore, FDG transport, from the blood to the tissues is regulated by the number and type of specific facilitative glucose transport proteins, known as GLUT. Characteristics of various GLUTs are presented in Table 1²⁻⁴.

The over-expression of GLUTs, especially GLUT1 and GLUT3, is one component to the increased glucose metabolic rate observed in malignant tissues. Inflammatory tissues also have a high expression of GLUT1⁵, leading to one possible association with false positive findings in PET studies⁶. In many tumor types, the degree of FDG uptake correlates with the expression of GLUT1 which is likewise related to tumor grade^{7,8} but not necessarily all malignancies^{9,10}. The insulin-dependent GLUT4 explains the glucose metabolic characteristics of the heart, fat and skeletal muscle. An understanding of the characteristics of the various glucose transporter proteins, specifically the pattern of expression and up-regulation, provides insight into the determinants of physiological, pathological and nuisance uptake of FDG. The activity level of hexokinase, which may also be up-regulated in malignant tissues, also significantly influences the glucose metabolic rate of the particular tissue and therefore, the degree of FDG uptake^{11,12}.

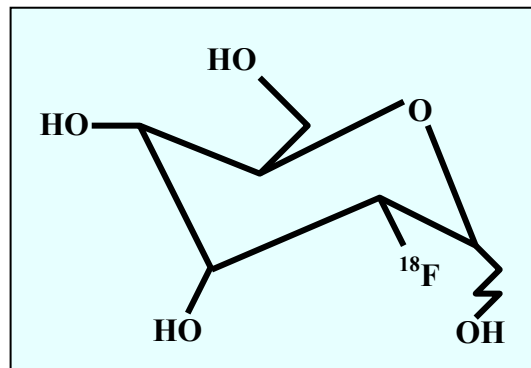

Figure 6. Chemical structure of [^{18}F]fludeoxyglucose (FDG)

Table 1

Characteristics of facilitative glucose transporters (GLUT)			
Protein	Expression	General Function	Up-regulation
GLUT1	All tissues but abundant in brain (vascular) and erythrocytes	Basal uptake	Over-expressed in nearly all cancerous cells (exception of some brain malignancies). Increased in chronic ischemia.
GLUT2	Liver, pancreatic islet cells	Glucose sensing (low affinity) and some fructose transport	Over-expressed in gastric cancer and reduced in pancreatic cancer
GLUT3	Brain (neuronal)	Supplements GLUT1 in high energy demand tissues (high affinity)	<i>Over-expressed in cancerous cells (brain, breast, gastric, head and neck, lung, meningiomas, ovarian)</i>
GLUT4	Muscle, adipose tissue, heart	Insulin-responsive (high affinity)	Over-expressed in some cancers (breast, gastric, lung) and reduced in others (pancreatic). Increased in acute myocardial ischemia.
GLUT5	Intestine, testis, kidney, erythrocytes	Fructose transport	Over-expressed in lung cancer
GLUT6	Spleen, leukocytes, brain		
GLUT7	Liver		
GLUT8	Testis, brain, blastocyst		
GLUT9	Liver, kidney		
GLUT10	Liver, pancreas		
GLUT11	Heart, muscle		
GLUT 12	Heart, prostate		Over-expressed in some breast and prostate cancer cell lines

Adapted From: Medina and Owens, 2002, Joost and Thorens, 2001 and Macheda, Rogers and Best, 2005.

Distribution

The biodistribution of FDG reflects the pattern of glucose metabolism by the various tissues throughout the body. As will be discussed throughout this lesson, because FDG is a physiologically-based tracer, the distribution will be influenced by a host of factors. Figure 7 displays two whole-body FDG PET scans.

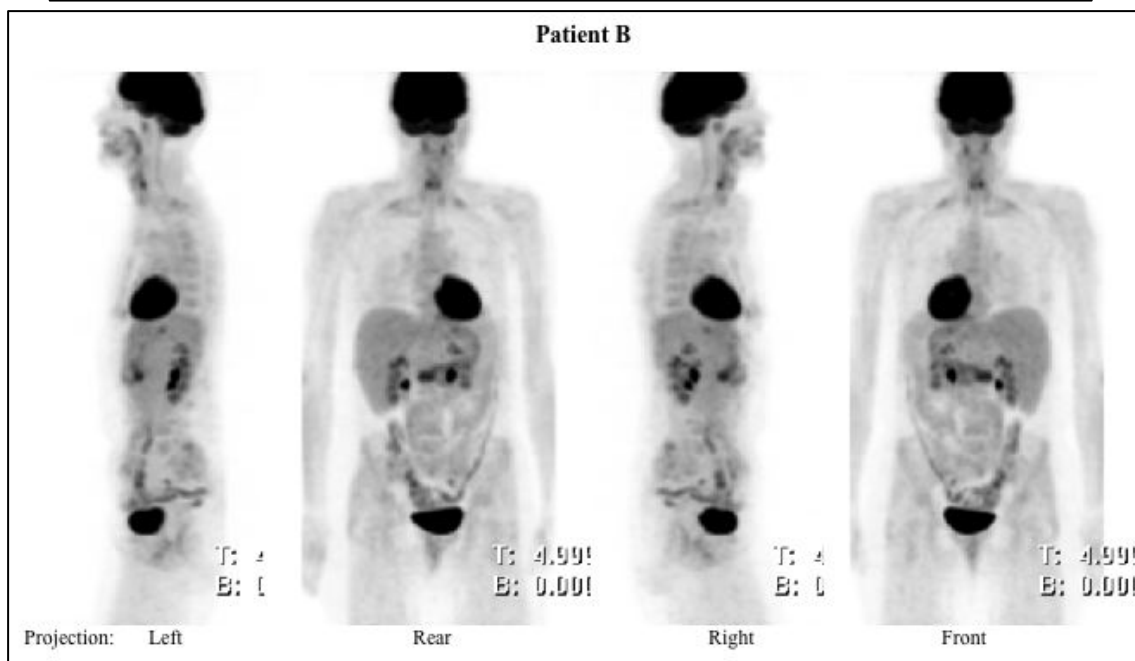
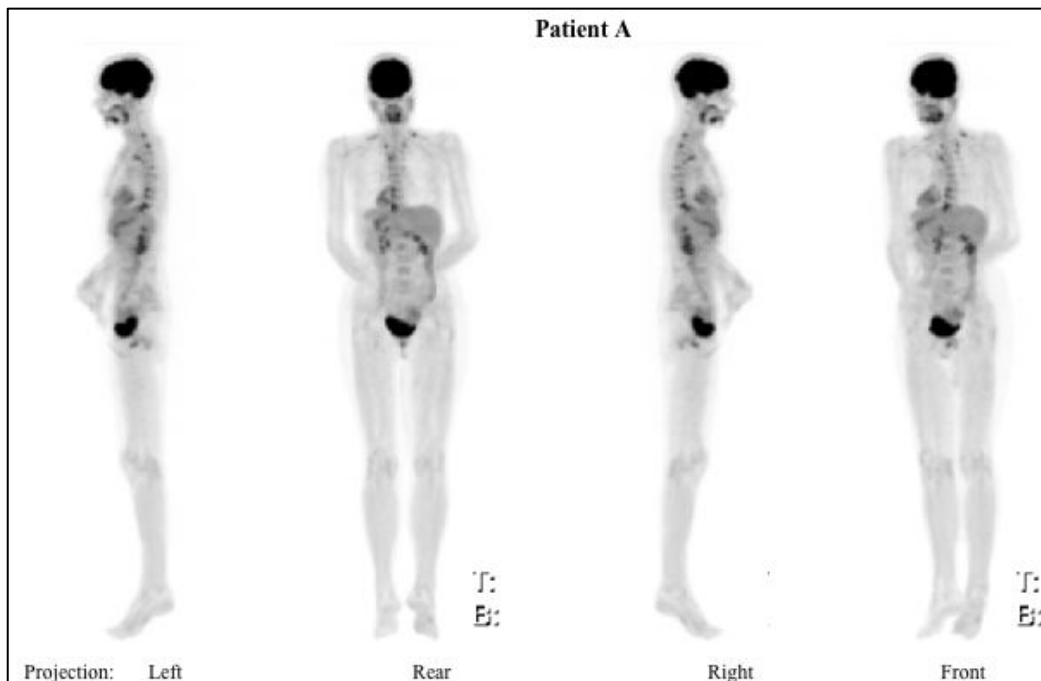

Figure 7. Maximum Intensity Projections (MIPs) of whole-body FDG PET scans. Patient A was a 50 year old female with melanoma imaged 123 minutes post-injection of 10.27 mCi FDG. At the time of injection, she had a blood glucose level of 80 mg per dL. Patient B was a 44 year old female with head and neck cancer imaged at 86 minutes post injection of 10.54 mCi FDG. At the time of injection, she had a blood glucose level of 91 mg/dL. High uptake is seen in the brain, heart and urinary tract. Liver, spleen and bone marrow have intermediate uptake. GI tract and lymphoid tissue in the head and neck are also apparent. Both patients were pre-treated with alprazolam and were imaged at approximately 90 minutes post-FDG administration.

Areas of consistently high FDG uptake are the brain and the urinary tract. Approximately 20% of the administered dose is excreted unchanged within the first two hours post-administration¹ since FDG, unlike glucose, is not reabsorbed by the kidney tubules. Areas of intermediate, but consistent uptake are the liver, spleen, thyroid and bone marrow (in patients without drugs or conditions that would potentially stimulate bone marrow activity). Other tissues that may exhibit physiological uptake are the

salivary glands, lymphoid tissues in the head and neck, thymus (especially in children), lactating breast and areola, uterus (during menses), GI tract, and skeletal and smooth muscle¹³.

Cardiac visualization on whole-body FDG imaging exhibits a large degree of unexplained intra- and intersubject variability most likely the result of varying levels of insulin present. For example, at the University of Iowa, 91 whole-body FDG studies performed in the fasting state were examined for cardiac uptake. Fifty-two (57%) had visualized uptake in the left ventricle (LV). The average whole blood glucose level at the time of injection was 74.1 ± 23.7 for all studies, and 73.2 ± 26.7 , and 75.2 ± 22.2 mg/dl for the subsets of studies for which the LV was and was not visualized, respectively. Five of the patients had studies performed on more than one occasion. With two of these patients, the LV was visualized on one but not the other study. For the two patients in which the LV was visualized in both studies, the mean difference in SUV was 5.4, with essentially no difference in fasting glucose levels. One subject did not visualize the LV on either study. (unpublished results).

Radiation dosimetry

The radiation dosimetry for FDG as reported in the monograph¹ for Fludeoxyglucose F 18 and modified by the sample package insert available from the FDA is presented in Table 2.

The effective dose is 0.1 rem per mCi (0.027 mSv per MBq) with the critical organ being the bladder wall. Slightly different estimates have been published by MIRD¹⁵. The dose to the bladder wall can be significantly reduced by encouraging the patient to be well-hydrated prior to the study and to void frequently. Voiding prior to imaging will not only reduce the radiation dose to the bladder wall but will also improve image quality. Germanium-based transmission imaging adds only a negligible additional radiation burden (e.g., $0.20 - 0.26$ mSv = 20 mrem)¹⁶. With the advent of new PET/CT cameras, a larger radiation dose may be accrued from the CT scan (whole body effective dose = 25 mSv = 2.5 rem) than from the FDG¹⁷. Fetal dose estimates from a 10 mCi FDG dose ranged from 0.3 rem for a full-term (9 month) to 1.0 rem for early pregnancy¹⁸. Excretion of FDG into breast milk was very low ($5.54 - 19.3$ Bq per MBq) resulting in a cumulative dose to the infant of 0.085 mSv, below the 1 mSv recommended limit. However, the close contact between the mother and the infant during breast feeding actually imparts a larger radiation dose than the dose from ingestion of the milk leading to the recommendation that the mother not feed the infant for the short period of time (12 – 24 hours) in which FDG is present in her body^{1,19}.

Table 2

Radiation dosimetry from 5, 10, 15 or 20 mCi doses of FDG					
Organ	mrem per mCi	mrem per 5 mCi dose	mrem per 10 mCi dose	mrem per 15 mCi dose	mrem per 20 mCi dose
bladder wall-no void	629	3,145	6,290	9,435	12,580
bladder wall-2 hr void	440	2,200	4,400	6,600	8,800
bladder wall-1 hr void	220	1,100	2,200	3,300	4,400
heart	240	1,200	2,400	3,600	4,800
brain	96	480	960	1,440	1,920
kidneys	77	385	770	1,155	1,540
uterus	74	370	740	1,110	1,480
ovaries	55	275	550	825	1,100
testes	55	275	550	825	1,100
adrenals	51	255	510	765	1,020
small intestines	48	240	480	720	960
liver	44	220	440	660	880
pancreas	44	220	440	660	880
spleen	44	220	440	660	880
red marrow	41	205	410	615	820
lungs	41	205	410	615	820
thyroid	36	180	360	540	720
other tissues	41	205	410	615	820
effective dose (mrem)	100	500	1,000	1,500	2,000

Adapted From: USP-DI monograph for Fludeoxyglucose F18 dated 1/9/2003; Fludeoxyglucose F18 Injection Package Insert dated 4/18/1997.

Note: MIRL estimates as published in Hays, et al., 2002 ¹⁴

PHARMACOKINETIC MODELING

Compartmental and Non-Compartmental Modeling

The pharmacokinetic model utilized for FDG is represented schematically in Figure 8.

FDG and glucose compete for the same transporter proteins and the same metabolic enzymes.

However, glucose continues into the tricarboxylic acid cycle and is eventually metabolized to water and carbon dioxide, but FDG does not continue own this metabolic pathway. Instead, FDG becomes trapped within the tissues, providing an image that reflects the first two steps of glucose metabolism. The PET image, however, cannot differentiate between FDG within the tissues and FDG that has been phosphorylated (i.e., FDG-6-P).

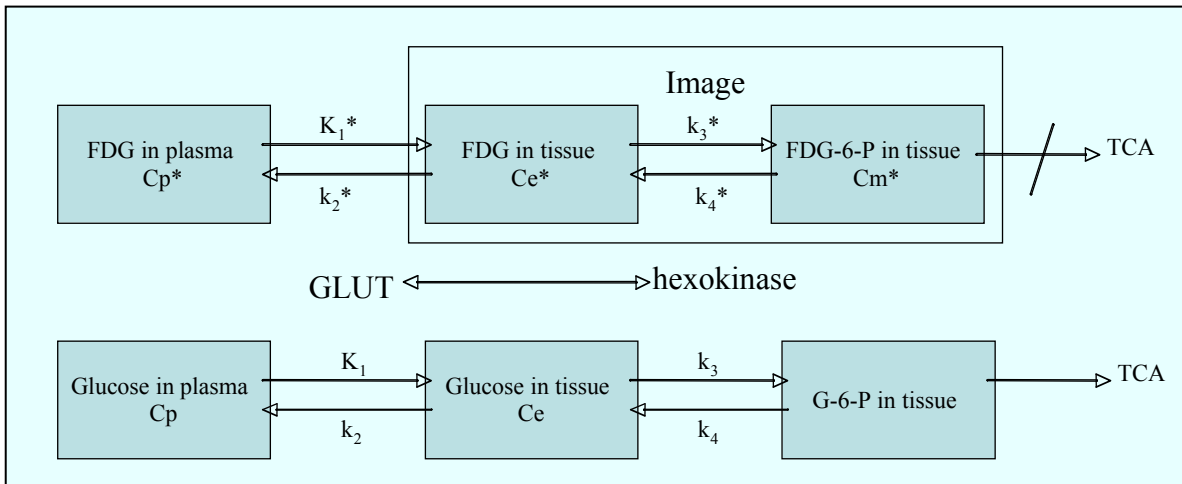

Figure 8. Pharmacokinetic model for FDG. Note that FDG and glucose operate in parallel and use the same active transport and metabolic enzyme systems. However, glucose continues into the tricarboxylic acid cycle (TCA) but FDG does not. The PET scanner cannot distinguish between $[^{18}\text{F}]$ in the form of FDG in the tissue and FDG-6-phosphate (FDG-6-P) in the tissue, therefore, the image reflects the concentration of both entities combined. Transport from the plasma into the tissue is facilitated by glucose transporter proteins (GLUT). Phosphorylation is catalyzed by hexokinase.

The pharmacokinetic models and the mathematical techniques utilized for the determination of the metabolic rate of glucose (i.e., MR_{glc}) from FDG imaging are presented in Appendix A. Reviews of the data requirements for various quantitative and semi-quantitative techniques are also available in Hoekstra, et al.²⁰ and Gambhir²¹.

Both compartmental and non-compartmental (e.g., Patlak approach^{22,23}) methods have been employed. These models require knowledge of the time-course of FDG concentration in both tissue and arterial plasma (either from direct sampling or image-based time-activity curve determinations) as well as the plasma glucose level to estimate the glucose metabolic rate. Because of the methodological rigors and time and personnel requirements of these techniques, full pharmacokinetic modeling is rarely employed in clinical situations, even though these techniques may offer the best discrimination between normal tissue and tumor²⁴. In lieu of MR_{glc} determinations, the standardized uptake value (SUV) is routinely employed in the evaluation of FDG uptake in clinical imaging.

Standardized Uptake Values (SUV)

Standardized uptake value (SUV), also referred to as DUR (dose uptake ratio, differential uptake ratio) or DAR (dose absorption ratio, differential absorption ratio), is a measure of the amount of tracer taken up into a particular tissue normalized by the dosage of tracer administered and the weight of the patient. The usual equation for SUV is:

$$SUV = \frac{\text{Concentration}\left(\frac{\mu\text{Ci}}{\text{mL}}\right)}{\frac{\text{Dose}(\mu\text{Ci})}{\text{Weight}(\text{g})}} = \frac{\text{Concentration}\left(\frac{\text{Bq}}{\text{cc}}\right)}{\frac{\text{Dose}(\text{Bq})}{\text{Weight}(\text{g})}}$$

where the concentration is that of the tissue of interest, either within a pixel or an ROI (region-of-interest). The assumption that 1 mL = 1 cc = 1 g is generally made. A uniform distribution of tracer throughout the body will result in an SUV of 1, therefore, SUV units can be conceptualized as multiples of a uniform distribution. If the ROI or pixel values are not displayed in concentration units that inherently factor in time and the conversion between scanner measurements and activity, the duration of imaging and pre-determined calibration factors must be factored into the equation. Careful consideration must be paid to the units in this equation. Alternatives to the above equation have employed the use of lean body mass (LBM)^{25, 26} or body surface area (BSA)^{26, 27} in lieu of actual body weight.

Since most image analysis software will display FDG images in SUV units (frequently the default unit option), accurate input into the image file header of the isotope administered (in this case [¹⁸F]), actual dose administered in the appropriate units (MBq or mCi), the measured weight of the patient in the appropriate units (kg or pounds) and the time between administration of the dose and imaging in appropriate units (minutes or seconds) is required for valid SUVs. To accomplish these ends, all patients must be weighed (and height measured if LBM or BSA options are employed) prior to FDG dosing. This weight may be used not only for the SUV calculation but also for both the determination of a weight-based dosage (when applicable) and for adjustments in imaging times based on body mass index (BMI). The syringe containing the FDG dose must be assayed in a dose calibrator both before and after administration to determine the net administered dose. The butterfly or IV tubing through which the dosage is administered may need to be assayed as well if the flush employed is insufficient to completely evacuate the tubing volume. Since accurate timing is critical, the use of stopwatches is advisable and the clock from which the time of the dose administration is determined and the scanner clock need to be synchronized. In all cases, only attenuation corrected images can be used to determine any quantitative or semi-quantitative parameter, including SUVs. And, fundamentally, the scanner must be calibrated to produce accurate measures of tissue concentration.

The SUV can be a critical piece of information, however, a number of factors influence the magnitude of the SUV leading to the alternative definition of the acronym, “silly useless value”²⁸. Four major

problems have been associated with the use of SUVs – patient size (weight), partial-volume effects, the uptake time, and the blood glucose concentration^{20, 29, 30}.

Patient size - Calculation of SUVs using total body weight assumes that all individuals have the same “normal” distribution of tracer. However, fat tissues have lower uptakes of FDG, resulting in distributions of SUVs correlated not just with tissue tracer uptake, but with subject body weight also³⁰. SUVs in non-adipose tissue may be inflated in markedly obese subjects due to effects on the denominator in the above equation. Significant reductions in weight during therapy, especially when due to loss in adipose tissue, has the potential to affect therapeutic monitoring via serial SUV measurements. Alternative normalization schemes that employ lean body mass or body surface area appear to be less dependent on patient characteristics³¹ and, in some reports, are more reliable indicators of actual tracer uptake. However, the majority of clinical research has been reported using the SUVs calculated from actual body weight.

Imaging time - For tracers that are completely extracted in a first pass and undergo no redistribution, only tracer decay will need to be factored into an SUV calculation. However, when an on-going metabolic process is being imaged, such as with FDG, the uptake, and therefore, the SUV is time dependent³². Within the acquisition time of a whole-body FDG scan, tracer concentration will increase due to continued uptake and

phosphorylation and decrease due to decay

and in some tissues, dephosphorylation. Therefore, within a particular facility, standard imaging times with decay correction should be employed to optimize the comparability of SUVs. Furthermore, when therapeutic monitoring is performed via serial FDG imaging, it is critical that the imaging of each potential tissue of interest be at approximately the same time post-injection in each scan to ensure comparability of the SUVs between scans

^{26, 29}. Figure 9 illustrates the change in SUV with imaging time and therapy.

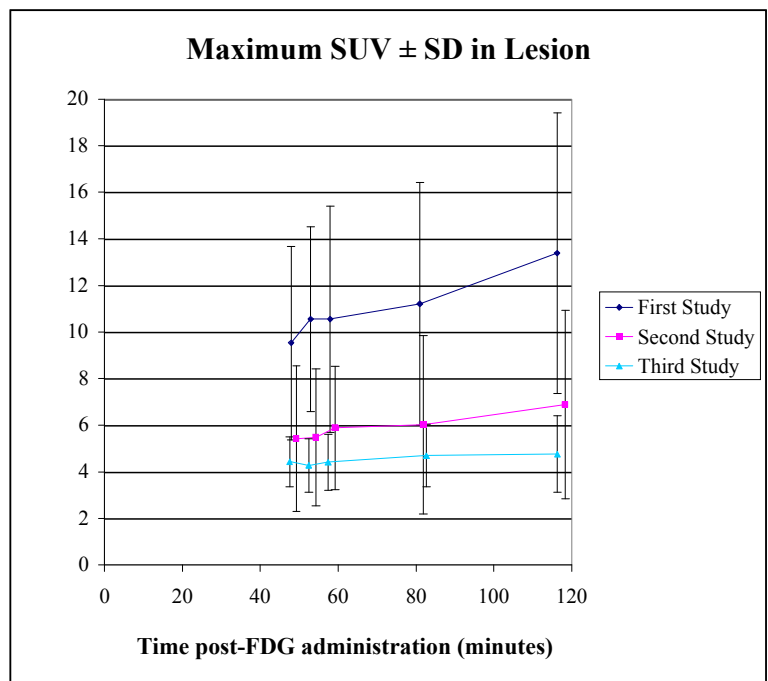

Figure 9. Change in SUV with time. The first study was conducted prior to any therapy. The second and third studies were conducted at 3 and 6 weeks, respectively, into a chemoradiation therapy protocol for esophageal cancer. The maximum SUV in esophageal lesions changed with imaging time post FDG injection for each therapeutic time frame.

Plasma glucose levels - FDG is an analogue of glucose which utilizes the same metabolic pathways as glucose. Glucose competes with FDG resulting in lower SUVs with increased plasma glucose levels³³. Essentially, when the blood glucose level doubles, the SUV will halve. Figure 10 illustrates the influence of blood glucose level on FDG uptake and SUV value for a highly metabolically-active tissue such as the brain.

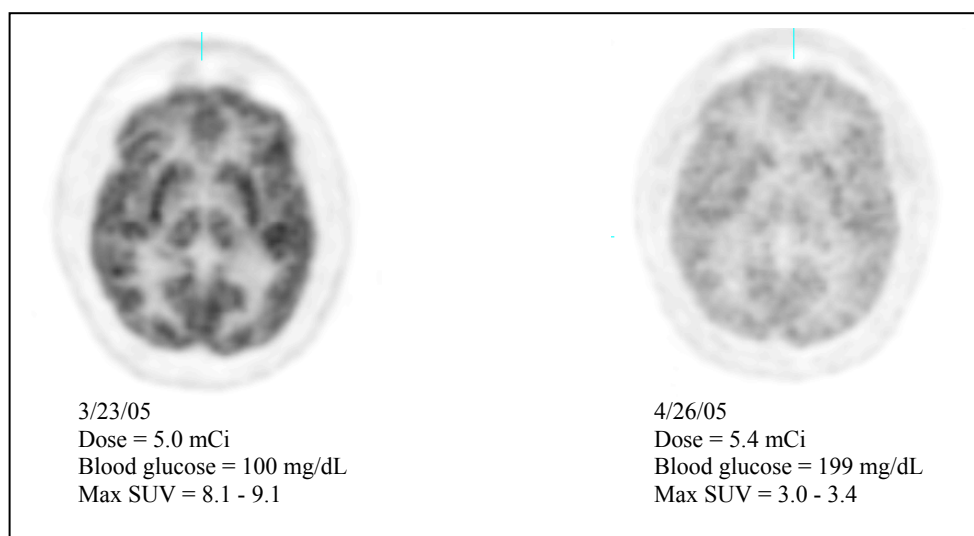

Figure 10. Influence of Blood Glucose Level on FDG Brain Study Quality. Both images were acquired at 50 minutes post-injection and are scaled equivalently.

Some authors have advocated normalizing SUVs by the blood glucose level³⁴ whereas, other authors have not found this to be useful³⁵. Even with essentially a normal plasma glucose level, high levels of insulin will drive FDG into tissues such as the heart, skeletal muscle

and adipose tissue, reducing the FDG available for uptake by tumors and other tissues of interest³⁶⁻³⁸. Issues relating to the influence of glucose levels on FDG uptake will be more extensively explored later in this lesson.

Partial volume, ROI and recovery coefficient effects - The recovery coefficient is the fraction of true activity measured or “recovered” in the reconstructed image of an object. The recovery coefficient (RC) is a function of the size of the object, with objects less than twice the resolution of the imaging system exhibiting RC values significantly less than 1. Partial volume effects refers to the fact that tomographic images do not segment along tissue-specific lines, but rather a given pixel is potentially a mixture of tissues. Again, partial volume effects are size-dependent. Larger objects are more likely to have a greater number of pixels that consist of only the tissue of interest than are smaller objects. Since SUVs are generally calculated for ROIs circumscribing a particular tissue or lesion, the size and shape of the ROI will determine the magnitude of the SUV.

Since all three of these factors influence the SUV, carefully drawn ROIs following the margins of a lesion that is relatively homogeneous and larger than twice the resolution of the scanner will produce the most accurate and reliable measurements. Small lesions may appear “colder” (or “hotter” if it is a “cold” lesion in a “hot” field) and have lower SUVs (or higher) than would be calculated for a larger lesion with the same tracer concentration because of the recovery coefficient, partial volume effects, and the mechanical difficulty in creating an appropriate ROI. The use of maximum, rather than mean, pixel values for lesion-based SUVs minimizes the latter problem but does not eliminate the first two. The reconstruction algorithm (filtered back-projection (FBP) or ordered-subsets expectation maximization (OSEM)) also will influence the magnitude of SUVs, especially maximum SUV, and therefore, needs to be consistently applied during serial imaging³⁹.

Application of SUVs - SUVs represent useful adjunctive information in the clinical decision-making process. With all of the problems (detailed above) associated with the calculation of FDG SUVs, their use as hard and fast criteria for the differentiation of benign from malignant tissue is unwarranted. However, with adherence to rigorous standardized protocols, their utility in the monitoring of therapy has been documented²⁶. Comparison of the SUV in the lesion to the SUV of a reference organ or tissue (e.g., liver) at each time point can assist in verifying that any changes observed are related to disease or treatment-related processes rather than technical issues²⁹.

Implications of the Pharmacokinetic Model

The important feature of this model is that glucose and FDG compete for the same transporter proteins and enzymes, therefore, physiological or metabolic processes or drugs that alter blood glucose levels will alter the biodistribution of FDG. FDG uptake will be maximized in tissues such as the brain and tumors that have significant levels of GLUT1 or GLUT3 by reducing endogenous glucose and insulin levels. FDG uptake will be maximized in tissues such as the heart, skeletal muscle and brown adipose tissue by stimulating the action of GLUT4 by the presence of endogenous or exogenous insulin^{36, 37}.

CLINICAL USE OF FDG

General Considerations

Dose of FDG - No absolute dose of FDG is universally employed due to differences between centers in camera sensitivity, imaging duration and uptake time. The dose employed is based on the offsetting goals of reducing the radiation exposure to the patient and minimizing the duration of imaging

necessary for adequate count-statistics (i.e., timer per bed position). The dose of FDG employed is generally 0.14 – 0.21 mCi per kg or 5 – 20 mCi, with 10 mCi being the most commonly employed dose^{1, 13, 29}. Doses at the lower end are generally used for brain and cardiac studies due to the high metabolic rate in these tissues. Both dose and imaging times are frequently adjusted for weight and/or body mass index (BMI)⁴⁰. Everaert, et al.⁴¹ recommended 0.22 mCi per kg for optimal imaging (3minutes emission, 2 minutes transmission per bed position) at 60 minutes post-injection on LSO (lutetium orthosilicate) cameras. Pediatric patients are generally dosed at 0.14 – 0.20 mCi per kg¹³.

Time to peak concentration/peak diagnostic effect - The time to peak concentration is dependent on the metabolic rate of the particular tissue¹. In highly glucose metabolically active tissue such as the brain, peak concentrations generally occur by approximately 30 minutes with imaging between 30 and 60 minutes. See Figure 11^{24, 42} for sample time-activity curves of FDG in the arterial blood and brain. Since cardiac uptake is augmented with insulin creating a highly metabolically active state (see below), viability imaging is also performed commencing before 60 minutes in most cases. Because of the diversity of metabolic rates exhibited by benign and malignant tissues of interest, oncologic imaging is begun anywhere from 45 minutes to 3 hours post injection. A second set of images acquired later in time to assess not only the magnitude of FDG uptake but the change with time are obtained in some facilities¹³.

Route of administration - FDG is administered by IV injection via IV catheter in an upper extremity vein, preferably the antecubital vein. If there is high likelihood of axillary node involvement (e.g., breast cancer), the IV catheter is placed in the contralateral arm to the primary tumor site. If there is bilateral disease, some Centers will consider administration via a foot or ankle vein. As mentioned earlier, the syringe should be assayed both before and after injection and, if the IV is no longer needed for administration of other medications, the catheter and tubing may also be assayed for residual FDG. FDG is not injected into indwelling catheters or previously placed lines unless IV placement fails due to the risk of “hang-up” of the dose in the larger volumes of these catheters.

If IV access is impossible, there is limited literature to support the use of oral FDG. The dose and image timing is generally the same as with IV administration. Because of the uncertainty of the exact dose systemically available (due to time course and extent of absorption, and risk of sequestration in the mouth, throat and/or stomach), SUVs should not be calculated. These methodological limitations generally restrict the utility of this route to brain studies only.

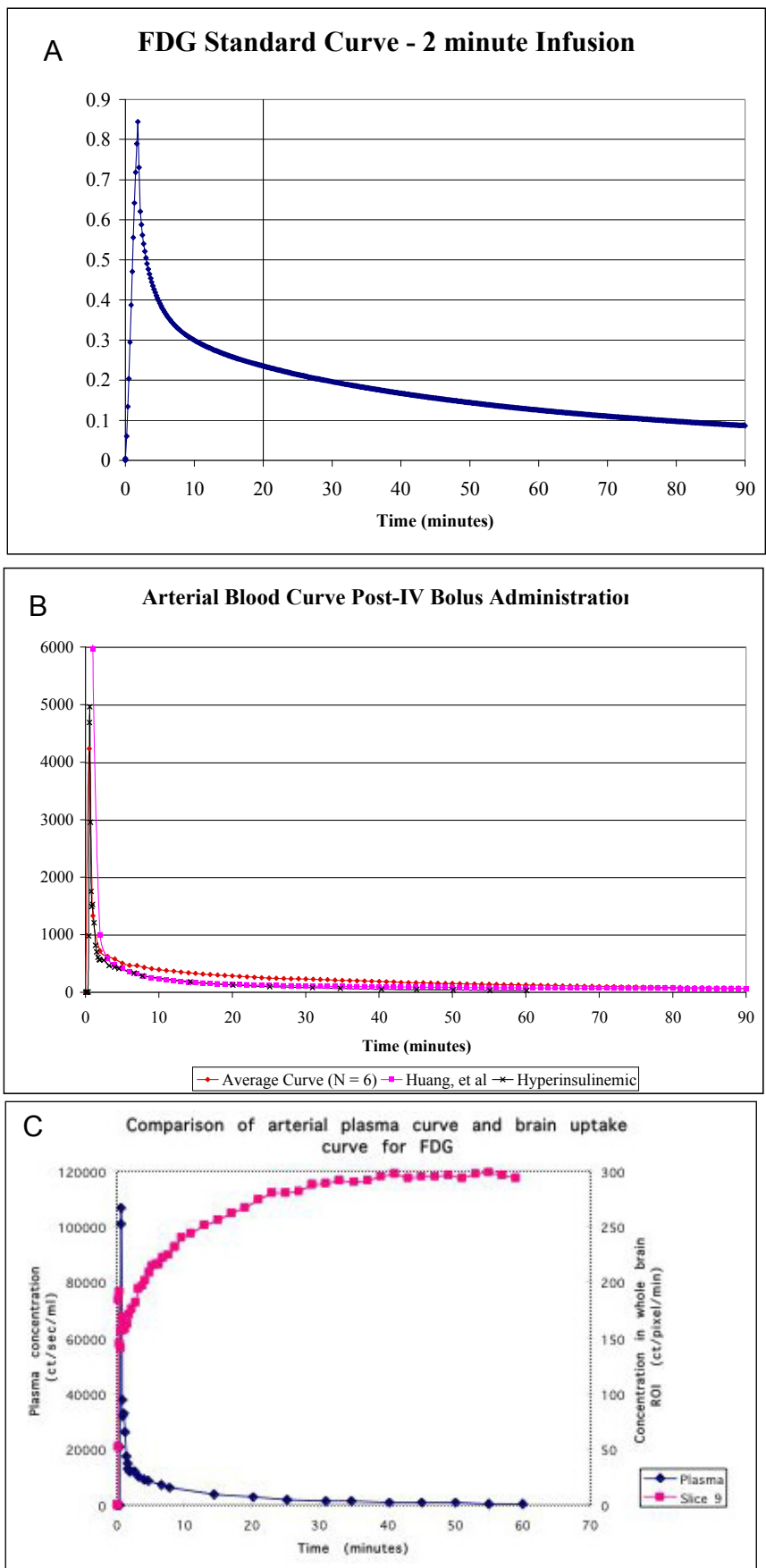

Figure 11. FDG time-activity curves in the arterial plasma. The curve in A is a standard curve after a 2-minute infusion of FDG as reported by Graham, et al. (2000). The curves in B are after a bolus administration as derived from Huang, et al., (1983), the mean of 6 subjects sampled at the University of Iowa, and a hyperinsulinemic subject. The curve in C is the above hyperinsulinemic subject and her corresponding brain uptake curve.

Patient History - A detailed patient history is required for optimal FDG imaging. The following information should be acquired ^{13, 29, 30} from all patients:

- History of diabetes or hyperglycemia
- History of claustrophobia
- Patient's ability to lie still for the duration of the study
- Patient's ability to put his or her arms overhead for an extended period of time (whole-body and cardiac)
- Current medications
- Pregnancy or breast feeding status (females of child-bearing potential)

Additional pertinent information is needed for specific FDG applications (see below). Ideally, all patients are contacted, generally by phone, prior to the scheduled PET study. The purpose of this telephone call is twofold – to secure the patient-specific information needed for optimal scheduling and imaging (e.g., weight, diabetes status, medications, medical history) and to educate the patient regarding the necessary pre-scan instructions (e.g., diet, fasting, exercise, blood glucose levels).

Patient Preparation - All patients should be instructed to fast, consuming only water, for a minimum of 4 hours before FDG administration. Fasting is necessary to not only reduce blood glucose levels but to also reduce serum insulin levels. Adequate hydration should be encouraged to facilitate urinary excretion and ease of IV access. Patients on intravenous fluids should have solutions containing dextrose or parenteral feedings discontinued 4 to 6 hours prior to FDG administration. Parenteral feedings are then gradually re-introduced after imaging is completed. Diabetic patients need to have their blood glucose levels stabilized to levels below a maximum of 200 mg per dL without the immediate use (i.e., within 1.5 hours) of IV or short-acting subcutaneous insulin. For many patients, this level of glucose control may require a coordinated effort by all members of the patient's diabetic care team. Many Centers request that the patient consume a low carbohydrate/high protein diet the night or day before the FDG study to minimize both blood glucose and insulin levels. The morning dose of oral anti-diabetic agents may be taken, although some Centers request that all diabetic medication be held until after the study. Generally, scheduling diabetic patients early in the morning (0800 or 0900) is advisable whenever possible. Since these patients will not have eaten breakfast and will have taken their oral anti-diabetic medication, PET Center staff should be prepared to diagnose and treat possible hypoglycemic reactions.

Patient Arrival - All patients should have their blood glucose level determined upon arrival at the PET Imaging Center. Most hospitals have policies and procedures in place for the calibration, maintenance and operation of glucometers. If blood glucose levels are greater than 150 – 200 mg per dL, most PET

Centers will reschedule the patient for another day. If the clinical imaging schedule will accommodate a wait of a minimum of 1.5 hours, the use of intravenous regular insulin may be considered to reduce blood glucose levels. The pharmacokinetics of intravenous regular insulin makes this option feasible⁴³. The onset of effect is 10 – 30 minutes with peak effects at 15 – 30 minutes, but most importantly, the

duration of effect is only 30 to 60 minutes. The dose usually employed is 0.05 units per kg with modifications based on diabetic medication history, food intake and weight. Generally, insulin is not used to reduce the blood

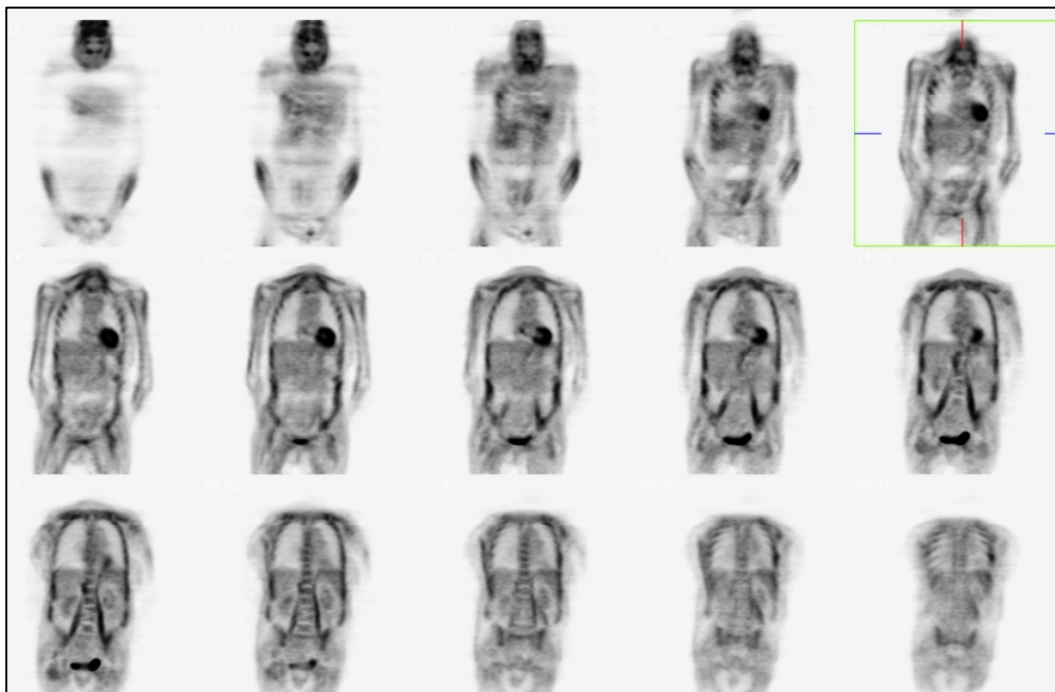

Figure 12. Effect of inadvertent subcutaneous administration of insulin on FDG images. The insulin dose resulted in widespread skeletal muscle and cardiac uptake of FDG. Images are attenuation-corrected.

glucose level. It should be emphasized that the IV insulin is only used if an adequate wait time is feasible. Figure 12 illustrates the effects of subcutaneous insulin on whole body FDG image quality.

Brain Imaging

Uses - Since the brain runs nearly exclusively on glucose, FDG imaging is used to evaluate the integrity of brain metabolic function. Although a multitude of research and clinical brain disorders could potentially be evaluated with FDG imaging, the primary clinical indications are in the evaluation of patients with epilepsy and in the differential diagnosis of dementia.

Uptake conditions - The pattern of glucose uptake in the brain will reflect both the underlying pathology present as well as the stimulatory conditions at the time of tracer uptake (e.g., auditory, visual stimulation). Brain mapping constituted an early research use of FDG and is still used for activations of long duration. For this reason, most clinical brain studies are conducted under standardized, controlled conditions consisting of uptake in a quiet, darkened room with eyes open and

ears unplugged. These conditions should be maintained until the patient is moved to the scanner for imaging, but at a minimum, for 20 minutes. This time period is based on the time-course of FDG activity in the blood and uptake kinetics in the brain. See Figure 10 for the effects of blood glucose level on FDG brain uptake.

Epilepsy - FDG imaging is used in epilepsy in conjunction with other imaging and diagnostic modalities for the identification of seizure foci⁴⁴. If the seizure focus can be identified, and is amenable to surgical resection, the seizure can possibly be mitigated or cured⁴⁵. In epilepsy, the pattern of glucose metabolism is dependent on the ictal status of the patient at the time of imaging. Ictally, the seizure focus is hypermetabolic. However, since FDG uptake is not based on first-pass kinetics but rather on an extended metabolic process, capturing an ictal event with FDG is very difficult and is rarely done. Rather, the fact that the seizure focus is hypometabolic interictally is utilized diagnostically. The peri-ictal phase may entail a mix of hyper- and hypometabolism lasting as long as 24 – 48 hours post-event⁴⁶. Therefore, patients should be interviewed about seizures within the day or two prior to imaging and monitored during the uptake phase for seizure activity. Some PET Centers monitor their seizure patients with EEG during uptake for this reason. Figure 13 presents an FDG study in a patient with right temporal lobe epilepsy.

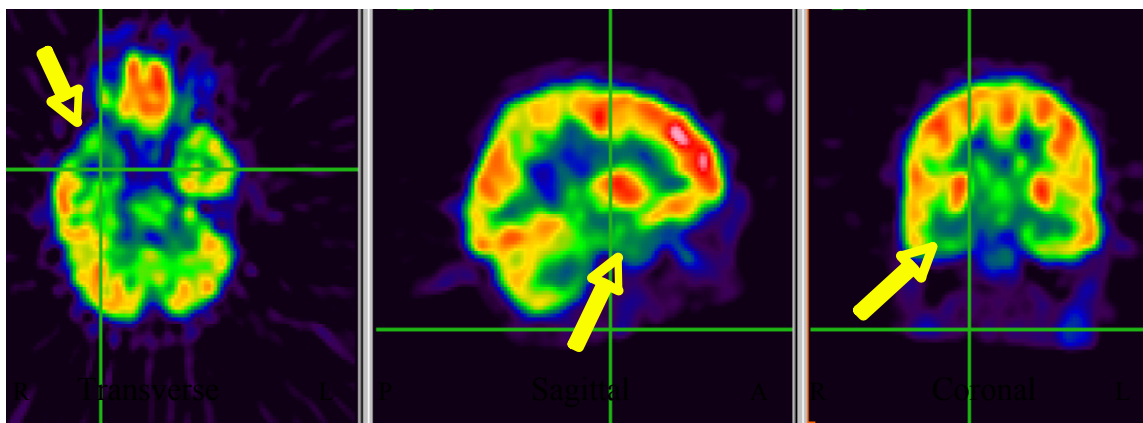

Figure 13. Epilepsy imaging for identification of seizure focus in epilepsy. Patient was an 11 year old girl with right temporal lobe epilepsy. Imaging was performed on 5/95. Arrows identify the hypometabolic focus. Right temporal lobectomy was performed on 10/96. Patient is currently seizure-free.

Alzheimer's Disease - FDG imaging has proven utility in the diagnosis of Alzheimer's disease (AD) providing a more accurate and earlier diagnosis than clinical symptoms alone. Even though this diagnostic accuracy has been well documented, FDG PET is not routinely used in the diagnosis of AD because the advantage of an early and accurate diagnosis for a disorder that does not have definitive and prognosis-altering treatments is of questionable health care policy value. Therefore, CMS has

established criteria for the reimbursable use of FDG imaging, specifically, for the differential diagnosis of AD from frontotemporal dementia (FTD). The criteria are presented in Figure 14. Both AD and FTD present distinctive metabolic deficit patterns, specifically, parietal-temporal hypometabolism in AD and fronto-temporal hypometabolism in FTD. See Figure 15.

CMS Criteria for Reimbursement for FDG Imaging in Dementia

Medicare covers FDG-PET for either

- The differential diagnosis of both Frontotemporal dementia (FTD) and Alzheimer’s disease (AD) under specific requirements, or
- Use in a CMS-approved practical clinical trial focused on the utility of FDG-PET in the diagnosis or treatment of dementing neurodegenerative diseases.

For use in the differential diagnosis of FTD and AD, an FDG-PET scan is considered reasonable and necessary from patients

- with a recent diagnosis of dementia and
- documented cognitive decline of at least 6 months
- who meet diagnostic criteria for both AD and FTD.

These patients have been evaluated for specific alternative neurodegenerative diseases or causative factors, but the cause of the clinical symptoms remains uncertain.

Patient’s onset, clinical presentation, or course of cognitive impairment is such that FTD is suspected as an alternative neurodegenerative cause of the cognitive decline. Symptoms such as

- social disinhibition,
- awkwardness,
- difficulties with language, or
- loss of executive function are more prominent early in the course of FTD than the memory loss typical of AD.

Patient has had a comprehensive clinical evaluation (as defined by the AAN) encompassing:

- A medical history from
 - the patient and
 - a well-acquainted informant (including assessment of ADL)
- Physical and mental status examination
 - including formal documentation of cognitive decline occurring over at least 6 months
 - aided by cognitive scales or neuropsychological testing
- Structural imaging such as MRI or CT
- Evaluation has been conducted by a physician experienced in the diagnosis and assessment of dementia.

Evaluation of patient

- did not clearly determine a specific neurodegenerative disease or other cause for the clinical symptoms, and
- information available through FDG-PET is reasonably expected to help clarify the diagnosis between FTD and AD and
- help guide future treatment

FDG-PET is performed in a facility that has all the accreditation necessary to operate nuclear medicine equipment. Reading of the scan should be done by an expert in nuclear medicine, radiology, neurology, or psychiatry, with experience interpreting such scans in the presence of dementia.

Figure 14. CMS Criteria for FDG Imaging in Dementia (available at <http://new.cms.hhs.gov/Transmittals/downloads/R31NCD.pdf>)

Although diagnosis of these disorders can be made by visual evaluation of the images, two commercially available software packages, NeuroQ™ (Syntermed, Inc., www.syntermed.com) and Alzheimer’s Discrimination Tool (PALZ) of PMOD (PMOD Technologies, www.pmod.com). Both of these packages incorporate comparisons of the patient’s image to a normal database for the

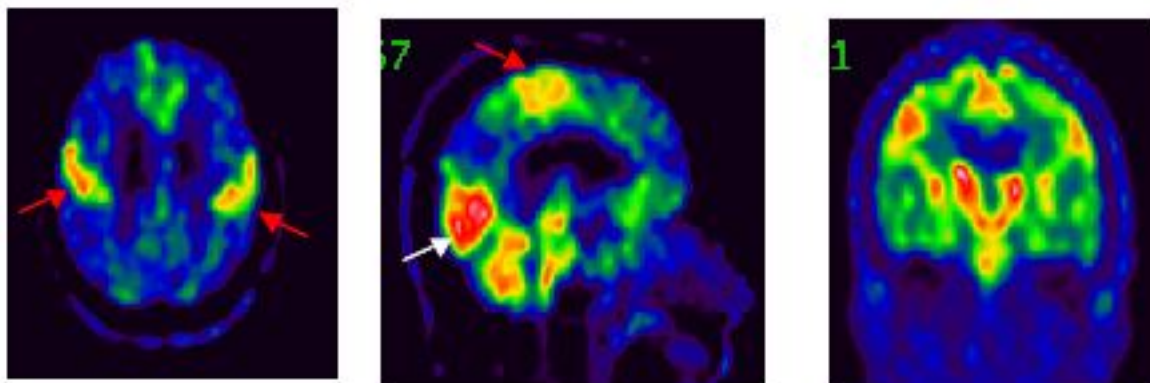

Figure 15. FDG imaging in Alzheimer's disease. Patient was a 53 year old female referred for evaluation of potential dementia. FDG images show significant hypometabolism in the parietal, temporal and frontal lobes with normal metabolism essentially limited to the occipital lobe and the motor strip only.

identification of areas of hypo- or hypermetabolism and to provide an estimate of the probability of AD. Differences between the two programs involve specified conditions for FDG uptake and whether patient age is factored into the normalization. NeuroQ uses FDG uptake conditions as described above whereas the PALZ module of PMOD uses an eyes-closed uptake condition. NeuroQ™ does not employ age-adjustment whereas, PMOD does (minimum age = 48 years). If one of these software packages will be used to augment the physician's image interpretation, the uptake conditions for the patient must be the same as those used for normal subjects in the software's database. A sample report for the PALZ module of PMOD is presented in Figure 16. A flash tutorial for NeuroQ™ is available at <http://www.syntermed.com/neuroq.htm>.

Cardiac Imaging

Uses - Cardiac imaging is used for the determination of myocardial viability. FDG imaging is always performed in conjunction with a myocardial perfusion scan. The perfusion (e.g., thallium, [^{99m}Tc] agent, [¹³N]ammonia, or [⁸²Rb]rubidium) and viability (FDG) scans are compared for identification of areas of match (i.e., adequate perfusion/adequate metabolism = healthy myocardium; no perfusion/no metabolism = infarcted myocardium) and mismatch (compromised perfusion/evidence of metabolism = ischemia). Patients with areas of mismatch are candidates for revascularization procedures to restore perfusion to the still viable but vulnerable myocardium.

Patient Preparation - The predominant glucose transporter in heart muscle is the insulin-dependent GLUT4. Therefore, insulin, either endogenous or exogenous, is needed to facilitate FDG uptake into the heart muscle. The goal is to balance the stimulation of endogenous insulin production, the actions of endogenous/exogenous insulin, while protecting the patient from hypoglycemia. Three approaches to achieve this balance are employed – oral glucose loading, intravenous glucose loading with or

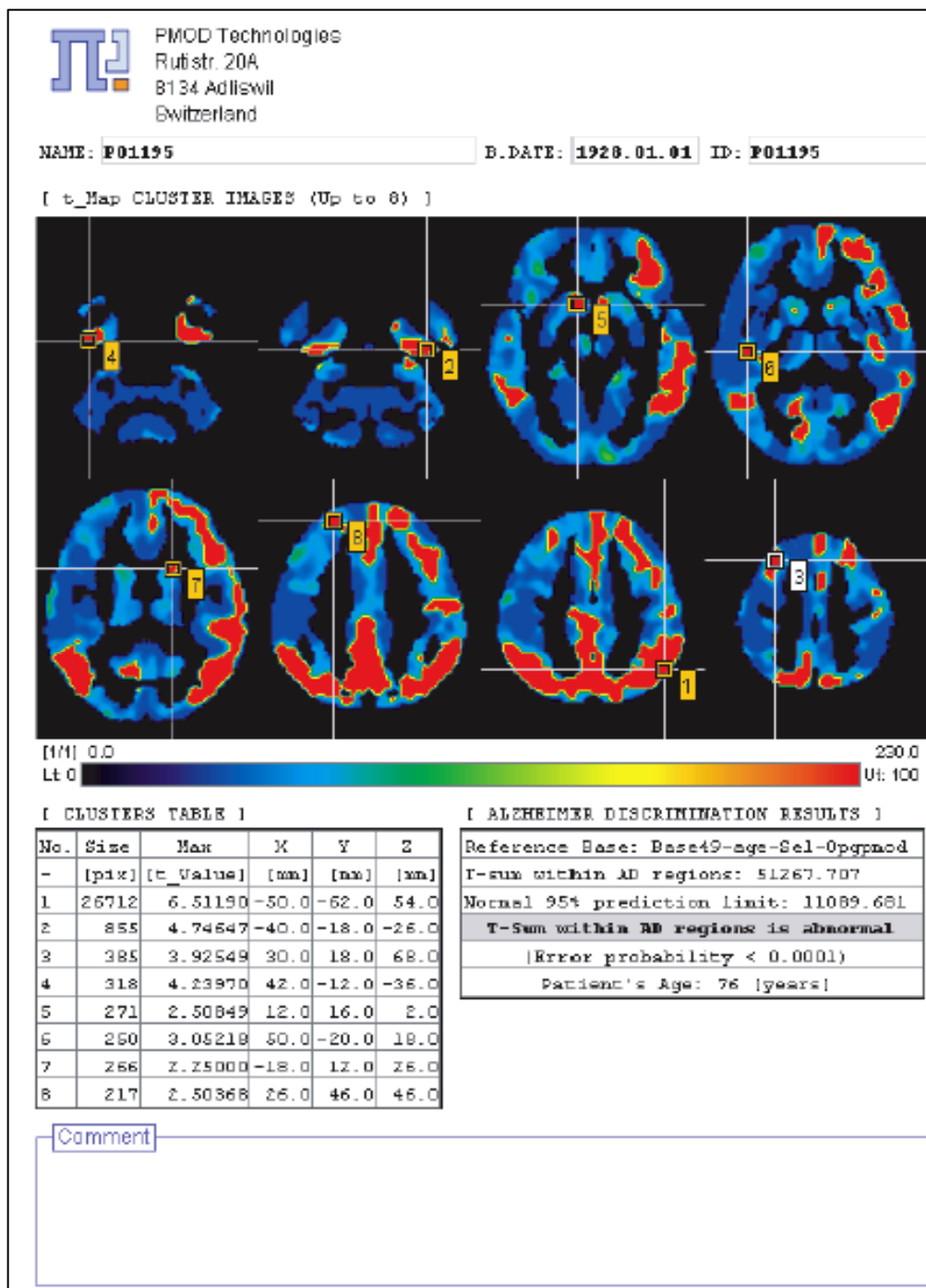

Figure 16. Sample Output from PMOD's Alzheimer's Discrimination Tool. PMOD Technologies. www.pmod.com/technologies/products/alzheimer_tool/alzheimer_tool.php

without supplemental insulin and hyperinsulinemic euglycemic clamp (Bax, et al., 2002). Patients with non-insulin-dependent diabetes frequently have relative insulin resistance making both the facilitation of FDG myocardial uptake and glucose management much more difficult (Vitale, et al., 2001). Protocols for optimal FDG cardiac imaging are complicated and beyond the scope of this lesson. An example of a protocol employing intravenous glucose and insulin adjusted for both body weight and diabetes status is available at <http://pet.radiology.uiowa.edu>.

Patient Monitoring - The degree of monitoring required for patients undergoing cardiac imaging is determined by the clinical status of the patient as well as the type of insulin-stimulating protocol utilized. Protocols employing oral glucose loading without supplemental insulin require less monitoring than the very labor-intensive euglycemic clamp. However the use of oral glucose poses the risk of unpredictable response due to incomplete or slow absorption, especially in diabetic patients with gastroparesis, or no response due to vomiting of the oral load. Intravenous dextrose with supplemental insulin provides more predictable responses to the glucose loading and therefore, a greater chance of diagnostic FDG uptake. In all cases, frequent monitoring of blood glucose is needed to ensure that the characteristic increase (indicative of glucose absorption) and then decrease (indicative of insulin release and/or action) is occurring which will facilitate the FDG transport into the myocardium. In addition, monitoring is needed to ensure that the patient is not becoming hypoglycemic. The PET Center staff should be prepared to detect and treat hypoglycemia at all times.

Imaging - Imaging generally consists of a rapid scout exam to ascertain whether tracer has been taken up by the myocardium or not and for positioning of the heart within the field-of-view. This scout exam can occur as early as 25 minutes post FDG injection. If uptake is apparent, then transmission

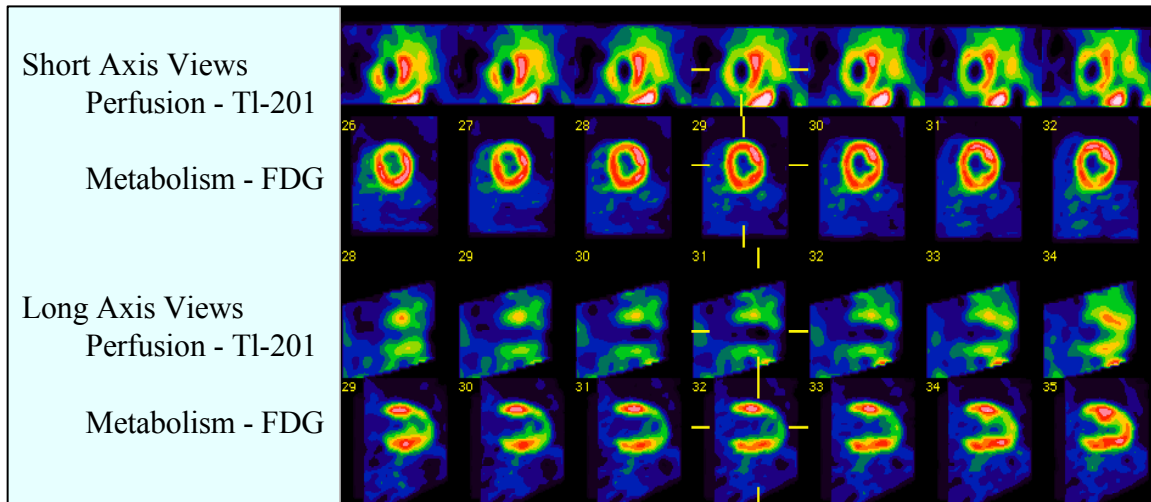

Figure 17. Example of cardiac viability imaging. Patient information: 57 yr old male with history of anterior wall infarction. Catheterization results indicated total occlusion of mid LAD and Cx arteries; 80% distal RCA and 50% obtuse marginal occlusion. Areas of “mismatch” (reduced perfusion with maintenance of metabolism) indicate tissue that will potentially benefit from revascularization procedures (i.e., angioplasty or by-pass graft). Areas of “match” indicate probable infarcted tissue that will not have function restored with revascularization.

and emission imaging may proceed generally at a time no earlier than 40 minutes post injection. If myocardial uptake is negligible after 40 minutes, the Nuclear Medicine physician needs to be notified regarding the choice for further actions. These choices include proceeding on with imaging even though the scan may be of technically questionable quality, further manipulation of glucose and insulin

doses with or without additional FDG administration, or rescheduling the patient for another day. An example of an FDG cardiac image paired with a thallium perfusion image is presented in Figure 17.

Oncologic Imaging

Uses - FDG is used for the diagnosis, initial staging, staging, re-staging, therapeutic monitoring therapy and evaluation for recurrent oncologic disease. The tumor types with proven utility and reimbursable status are presented in Figure 5. The purpose of the National Oncology Patient Registry is to collect the data needed to ascertain the utility of FDG across the spectrum of oncologic disease.

Patient History - In addition to the general patient history information needed as described above, specific inquiries should be made regarding the history of their malignant disease. Information on the type and site of the malignancy, type and dates of therapeutic interventions, and drug therapy is needed in all patients. Three consensus papers present guidelines for optimal tumor imaging with FDG. They were prepared by panels affiliated with the National Cancer Institute (NCI), the Society of Nuclear Medicine (SNM) and the European Organization for Research and Treatment of Cancer (EORTC).

- Consensus Recommendations for the Use of 18F-FDG PET as an Indicator of Therapeutic Response in Patients in National Cancer Institute Trials.²⁹
- Procedure Guideline for Tumor Imaging with 18F-FDG PET/CT 1.0.¹³
- Measurement of clinical and subclinical tumour response using [18F]-fluorodeoxyglucose and positron emission tomography: review and 1999 EORTC recommendations.³⁰

Timing of FDG imaging relative to therapeutic interventions - Pretreatment or baseline FDG scans should be acquired prior to treatment of any kind, however, when that is not possible, scans should be acquired less than 2 weeks into the regimen²⁹. Scans for the monitoring of therapy should be acquired at meaningful time points throughout the therapy, as exact timing will be disease and treatment-specific. See Figure 18 for an example of treatment monitoring with FDG PET imaging.

Clarifying the treatment monitoring utility of FDG is one of the goals of the NOPR database. Post-treatment scans should be acquired no earlier than 2 weeks after completion of chemotherapy^{29, 30}. The rationale for this time frame is that both false positive and false negative results may be obtained due to inflammatory responses and suppression of metabolic activity (stunning), respectively. A consensus has not been reached on the time frame for imaging post-radiotherapy. Some institutions wait as long as 3 months before evaluating the primary site, however, remote sites to the radiation field may be imaged at any time. The timing post surgery will frequently be dictated by wound healing and the time

course of reductions in inflammation or infection around the surgical site, both of which could result in false positive FDG scans.

Blood glucose levels - As discussed previously, blood glucose levels are critical determinants of FDG uptake characteristics, therefore, in all cases, the level must be measured upon arrival at the PET Center. The ideal level should be < 120 mg per dL for non-diabetic patients and < 200 mg per dL for diabetic patients. It is recommended that patients with blood glucose levels above these values should be rescheduled²⁹.

Timing of FDG imaging post-administration - As mentioned earlier, the time to peak FDG tissue activity will be determined by the glucose metabolic rate of the tissue of interest. Therefore, tumors of varying metabolic rates will have different peak times. Even primary tumors and their respective metastatic lesions will likely have different peak characteristics. An uptake time of at least 45 minutes post injection is required. Most institutions wait 60 to 90 minutes (60 ± 10 minutes is recommended by NCI²⁹) before beginning whole body imaging. Improvements in tumor-to-background contrast have been documented when comparing images acquired at two hours compared to the more usual one hour post-administration⁴⁷. Differences in acquisition parameters (due to patient factors such as weight and height and camera factors such as sensitivity and field of view) will alter the exact timing for a particular organ or tumor site. What is most critical is that the facility utilizes consistent timing across patients and definitely, across studies for the same patient.

In order to exploit the differences in GLUT1 expression and therefore, glucose metabolic rate, between inflammatory lesions, normal tissues and malignancies, some authors have advocated for dual time point imaging to increase sensitivity and specificity of FDG imaging. The evaluation of solitary

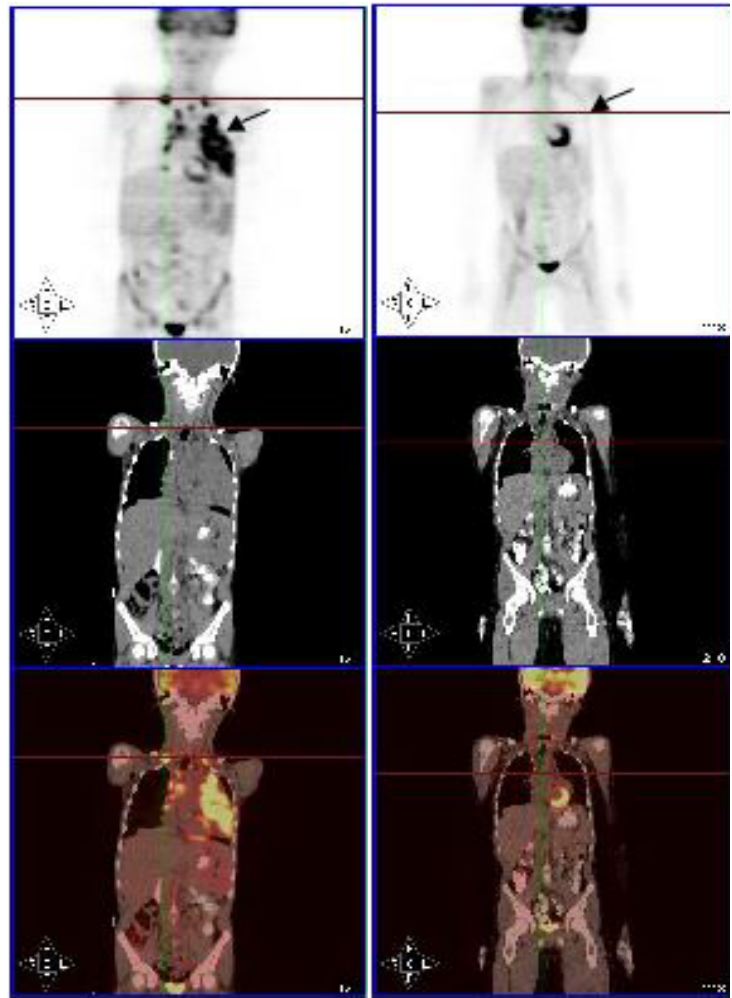

Figure 18. FDG imaging of the response to therapy. The patient is a 10 year old male with Hodgkins Lymphoma. The images (PET, CT and overlay) on the left are prior to therapy and the images on the right are after one cycle of chemotherapy. The arrow marks the lesions before and after therapy.

pulmonary nodules in the thorax (at 70 and 123 minutes post-injection)⁴⁸ and head and neck lesions (at 70 and 90 minutes post-injection)⁴⁹ are two anatomical areas reported to have improvements in diagnostic accuracy with this technique.

Uptake phase conditions - The patient should be weighed, height measured, and blood glucose level checked immediately upon arrival. If a medical history was not already secured prior to arrival, this information should be recorded. Particularly relevant to the physician interpretation of the scan will be a history of the use of colony stimulating factors, infections, recent surgeries or biopsies, or inflammatory processes. If oral sedation will be used, the dose should be given at least 30 minutes prior to administration of the FDG. If the patient is experiencing an uncomfortable amount of pain, they should take their own pain medication if available or in extreme cases, supplemental pain medication or conscious sedation can be used. Most institutions have policies regarding requirements for the administration of conscious sedation and these should be followed. In the case where any form of sedation is used, especially for patients that have the potential risk of airway obstruction (e.g., head and neck cancer), a pulse oximeter should be available for monitoring oxygen saturation levels.

If CT imaging will be used for attenuation correction (PET/CT), all clothing with metal components (e.g., zippers, snaps, etc.) and removable dental work should be removed. If the patient has implants or prosthetic joints (e.g., artificial hip), the technologist and physician should be informed due to the risk of image-based artifacts.

If oral or intravenous contrast will be used for PET/CT studies, a history regarding sensitivities to iodinated contrast agents should be taken (see below for further considerations). The first dose of oral contrast should be consumed before the administration of the FDG with subsequent doses taken toward the end of the uptake period in order to avoid muscle uptake of FDG from swallowing. It is recommended that the patient drink 500 mL of water after injection and before scanning. Postponing drinking until the early phase of FDG distribution is completed (approximately 20 minutes) will minimize the potential for muscle uptake in throat and neck from swallowing. The patient should be asked to void prior to injection of tracer to minimize the need to get up and move around during the uptake phase. If visualization of the pelvic area is of particular concern, a urinary catheter should be placed for aid in removal of the highly concentrated radioactive urine. Catheter placement should be made prior to FDG injection. Supplemental furosemide may be used to further augment urinary drainage from the collecting system and bladder (see below for further information).

The FDG dose should be administered via an IV catheter rather than by direct injection into the vein from the syringe. The use of a catheter minimizes the risk of infiltrating the dose and introducing error into the SUV calculations. The patient should be made as comfortable as possible, either in a reclining chair or lying on a bed or cart. During the uptake phase, the patient should be warm (using blankets from a blanket warmer if needed) and remain as quiet and relaxed as possible without speaking, eating, reading or watching television. Quiet music of his/her choice aids in relaxation. The goal throughout the uptake phase of FDG should be to minimize muscle activity either due to movement, tension, anxiety or activity and to avoid chills or shivering. It has been reported that undesirable muscle uptake of FDG may occur because of excessive physical activity a day or two prior to the PET study, suggesting that patients should restrict exercise prior to the study⁵⁰. However, this practice has not been rigorously investigated.

Immediately before imaging is to begin, the patient should be asked to drink any remaining oral contrast needed and to void again. Positioning on the scanner table should optimize patient comfort while minimizing the risk of movement. Since most whole-body imaging is performed with the arms extended overhead, a comfortable way to achieve this position needs to be developed by each PET Center.

Imaging - The field-of-view (FOV) for whole-body imaging is generally from the base of the skull to the proximal thigh. Head-to-toe imaging may be indicated when disease may exist in the upper skull or brain or in the lower legs (e.g., melanoma). Limited area imaging is indicated when disease is known to be limited to a specific areas of the body (e.g., head and neck cancer), however, examining the entire torso is useful for staging disease. A detailed discussion of imaging parameters is beyond the scope of the present lesson especially with the rapid changes in PET scanner technology. The application of consistent methods appropriate for the equipment available is critical for accurate interpretation of the images.

False positive and false negative risks - A number of physiological processes may create the potential for false positive or false negative findings in oncologic imaging. Commonly encountered sources of these errors are presented in Table 3¹³. False positive studies are generally associated with other highly metabolically active but not malignant processes such as inflammation, infection, wound healing or tissues such as lymphoid (e.g., tonsils), thyroid, active muscle or brown adipose tissue (BAT). False negative scans generally are associated with small lesions (due to partial volume

effects), and more differentiated or slower growing tumors. See the following text for examples of conditions that may produce false positive or false negative results.

PHARMACEUTICAL CARE ISSUES IN FDG IMAGING

Physiologically-based imaging is influenced by both processes of interest (e.g., pathologies) as well as nuisance processes. Some of the nuisance processes are avoidable or treatable. A number of drugs either play a potential adjunctive role in FDG imaging or may pose potential problems in image interpretation. The following processes and agents are of particular importance in FDG imaging.

Physiologically-based artifacts

Anxiety - Anxiety, stress, pain, and general discomfort all create a scenario in which there is increased muscle tension and possible increased movement. Increased muscle tension and movement leads to increased FDG uptake into voluntary muscle. This increased uptake is especially prominent and troublesome in the neck and shoulder regions, because it may potentially mask the uptake of tracer in other structures (e.g., lymph nodes) of interest. The solution to this problem lies in good patient care. First, it must be recognized that the patient is having a diagnostic procedure for a potentially life-threatening disorder (i.e., the Big “C” = cancer) and that it is natural that there will be a certain degree of apprehension regarding the outcome of the study. This anxiety and stress can be reduced by having the patient well informed about the imaging procedure and by creating a calm and supportive environment where patient comfort is a central goal. Many of these patients are in pain due to their disease or other chronic conditions. Maintaining adequate pain control during the procedure is important, either by ensuring that the patient take their regularly prescribed pain medication prior to the procedure or using additional pain medication during the procedure. Imaging-related discomfort (e.g., lying on their back in the scanner) should be mitigated by the use of patient supports (e.g., cushions under the knees) and careful positioning. When needed, sedation should be used. (See below for further discussion of this topic.)

Table 3

Sources of False Positive and False Negative Findings in FDG Oncology Studies
<p>False positive findings are potentially found from Physiological uptake Lymphoid tissues (in head and neck), thymus (especially in children) Salivary glands Breasts, lactating Skeletal muscle GI tract (smooth muscle) BAT Female genital tract (cycle – dependent)</p>
<p>Inflammatory processes Post-surgical, post-chemotherapy, post-radiotherapy (e.g., radiation pneumonitis) Granulomatous processes (e.g., sarcoidosis, fungal disease, mycobacterial) “itis”-type disorders (.e.g, thyroiditis, esophagitis, gastritis, pancreatitis, osteomyelitis, lymphadenitis, cholecystitis) Inflammatory bowel disease</p>
<p>Infection or trauma (e.g., fractures)</p>
<p>Benign neoplasms</p>
<p>Hyperplasia or dysplasia Grave’s disease Paget’s disease Cushing’s disease Fibrous dysplasia Bone marrow hyperplasia</p>
<p>False negative findings are potentially found from Small lesions (less than twice scanner resolution) Tumor necrosis Stunning from chemo- or radiotherapy Hyperglycemia or hyperinsulinemia Prostate carcinoma (especially well-differentiated) Some tumor types, especially well-differentiated forms of Hepatocellular carcinomas Genitourinary carcinomas Neuroendocrine tumors Thyroid carcinomas (I-131 positive) Bronchioloalveolar carcinomas Lobular carcinomas of breast Osteosarcomas Osteoblastic or sclerotic skeletal metastases</p>

Adapted From: Delbeke, et al., 2006

Coughing - Coughing creates muscular exertion in the abdomen, chest and neck muscles leading to nuisance FDG uptake in the skeletal muscle of these areas that can potentially mask lesions. See Figure 19 for illustration of this problem.

The best solutions to this problem lie in anticipating which patients pose the highest risk (e.g., lung cancer, head and neck cancer) and minimizing the cause of the coughing or pre-treating accordingly. Patients should be positioned during uptake and imaging in a manner that minimizes the need for coughing. Pre-treatment with a cough-suppressant may be useful, with sugar-free cough drops if needed. If sedation is needed, a pulse oximeter should be available for patients at-risk for airway obstruction.

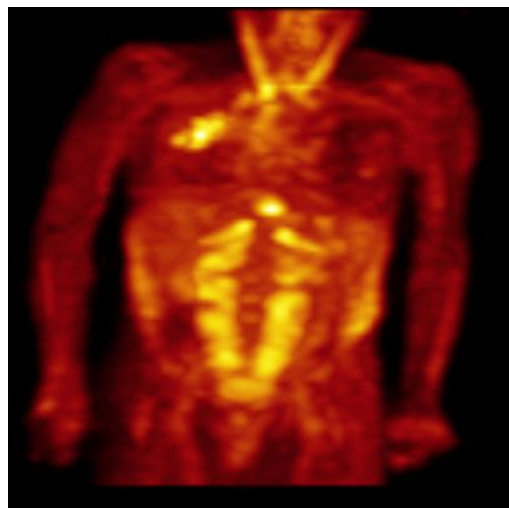

Figure 19. Effects of coughing on FDG uptake. The patient coughed continuously during the FDG uptake period creating intense uptake in the muscle of the neck and abdomen. The arrow marks the pulmonary nodule that was positive for FDG uptake and diagnosed as malignant.

Brown adipose tissue - Brown adipose tissue (BAT), also known as brown fat or “USA” fat (uptake in supraclavicular area fat) has become of increased

physiological importance since the advent of whole body FDG imaging. Tracer uptake that was frequently attributed to “muscle” activity in the past is now known, due to co-registered anatomical imaging, to reside in fat tissue. The distribution of this fat tissue (BAT) is particularly problematic since it tends to reside in the supraclavicular region, an area also involved with malignancies, as this region is a common site of lymph node metastases. These intense metabolic areas can result in false positive image interpretations.

The cause of the problem lies in the metabolism of BAT⁵¹:

- BAT generates heat in response to cold (nonshivering thermogenesis) or ingestion of food (diet-induced thermogenesis)
- Fat cells contain GLUT4 (insulin-dependent transporter)
- BAT expresses mitochondrial uncoupling protein which uncouples oxidative phosphorylation in the mitochondria, therefore, increasing the anerobic metabolism of glucose to produce ATP

The problem is of significant clinical importance. Hany et al⁵² found an overall incidence of 2.5% of symmetrical uptake in neck and upper chest areas. Yeung, et al⁵³ found that the incidence varied by location of the fat tissue (neck fat = 2.3%, paravertebral fat = 1.4%, perinephric fat = 0.8%, mediastinal fat=0.9%). Cohade et al.⁵⁴ found that 14.1% of studies had abnormal FDG uptake in the supraclavicular region of which only 4.3% was due to abnormal lymph nodes. Of the remaining false positive studies, 5.8% were due to muscle uptake and 4.0% to uptake in the fat tissue. In characterizing this abnormal uptake, they found that BAT was usually bilateral and generally symmetric. The SUV did not differ between abnormal lymph nodes and BAT uptake, but were lower

in muscle uptake. In addition, the incidence exhibited a ratio of 6:1 females to males. Further research⁵⁵ by this same group found that the expression of BAT (“USA-fat”) not only varied by gender (10.5% in females, 2.9% in males), but by age (23.8% ≤ 18 years old, 5.9% > 18 years old), and season of the year (13.7% in January through March and 4.1% in the balance of the year). Males expressing BAT uptake were younger and leaner than females with similar uptake. Figure 20 presents an example of BAT uptake.



Figure 20. FDG uptake in brown adipose tissue and skeletal muscle. Patient is an 18 year old female, status-post chemotherapy for neuroendocrine tumor with muscle and brown adipose tissue uptake.

Because uptake in BAT can be a serious challenge to diagnostic accuracy in FDG-PET, a number of solutions are available to mitigate the problem – both environmental and pharmacological. First, recognize the potential for the problem, especially in younger, thinner, female patients. In addition, recognize that the problem may be aggravated in colder months or when air conditioning is over-used. Keep the patient as warm, comfortable and “un-stressed” as possible in order to minimize stimulation of BAT via adrenergic mechanisms. Pharmacological interventions can be used to reduce BAT metabolism. Animal work has shown that BAT metabolism can be reduced by adrenergic blockade with reserpine or propranolol^{56,57} or by blocking peripheral-type

benzodiazepine receptors present in BAT⁵⁷. There has been a case report in the literature on the utility of propranolol in reversing BAT uptake⁵⁸.

In humans, benzodiazepines are routinely used for several reasons: (1) to relax the patient, which reduces FDG uptake due to muscle activity, (2)

to reduce BAT uptake of FDG by the direct action on benzodiazepine receptors, and (3) by an indirect effect of reducing stress-related adrenergic stimulation. Figure 21 presents an example of intense BAT uptake, which in this case was atypically asymmetrical, that was reversed by propranolol and alprazolam and midazolam administration.

To achieve high quality images, many PET Centers recommend oral sedation for all patients referred for the following conditions, to reduce both muscle and BAT uptake of FDG:

- Lymphoma
- Breast cancer
- Esophageal cancer
- Head and neck cancers
- Any anxious patient

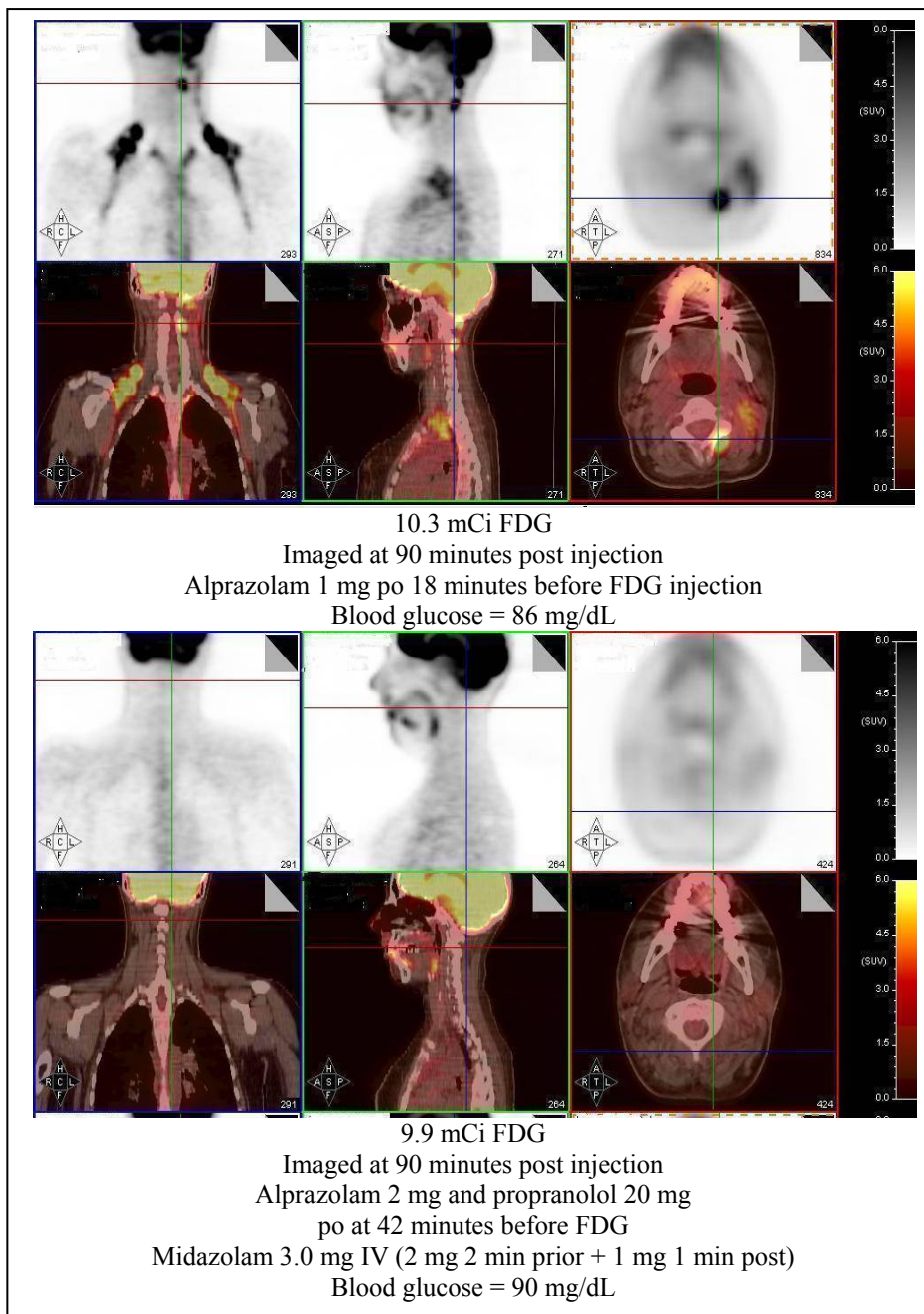

Figure 21. Example of the pharmacological influences on BAT (brown adipose tissue) uptake of FDG and the risk of misdiagnosis. Patient was a 19 year old female with a melanoma diagnosis. Interventions are as detailed above. Crosshairs are on an atypically asymmetrical BAT uptake which mimicked a nodal lesion. Second scan with BAT uptake blocked indicated no presence of uptake in that area (i.e., false positive first scan).

Since sedated patients should not be allowed to drive the remainder of the day, a driver should be present for transportation post-sedation. The need for a driver is a topic for the pre-PET scan telephone call. Oral sedation should be administered at least 30 minutes prior to FDG administration. Diazepam, lorazepam and alprazolam have all been used for this purpose. Table 4 presents relevant pharmacokinetic differences between these agents^{59, 60}.

Table 4

Pharmacokinetic Characteristics of Various Benzodiazepines

	Alprazolam	Diazepam	Lorazepam	Midazolam
Protein binding	High (80%)	Very high (98%)	High (85%)	Very high (97%)
Half-life (hours)	11 (6.3 - 26.9)	20 - 80 +	10 - 20	2.5
Active metabolites	None	at least 3	None	-----
Peak plasma (PO)	1 - 2 hours	1 - 2 hours	1 - 6 hours (SL - 1 hour)	onset within 0.5 (IV onset = 1.5 - 5 min)

Adapted From: USP-DI monograph for Benzodiazepines and for Midazolam

The ideal agent does not exist, but rapid onset and shorter half-life are distinct advantages for this use. Whenever sedation is administered, the PET Center should be prepared to provide pulse oximetry and have oxygen available if oxygen saturation levels fall below 90%. For patients requiring “conscious sedation” (e.g., midazolam and morphine), the applicable institutional policies and procedures must be followed.

Adjunctive agents

Iodinated Contrast Media - When CT imaging is done, in lieu of [⁶⁸Ge]-based transmission imaging, the use of contrast media poses the potential problem of introducing image artifacts from errors in attenuation correction. Artifacts can range from small alterations in the magnitude of SUV units to large focal increases in activity concentrations. Investigations with phantoms have revealed over-estimations of FDG concentrations with high, but not low, density barium⁶¹. Investigations in humans did find apparent “increased” FDG uptake in the small bowel with barium in comparison to negative contrast material (e.g., mannitol, water)⁶². The ability to distinguish intestinal wall from lumen and mass or node from bowel aided image interpretation in 19% of subjects in one study⁶³. Investigations of both visual interpretation and SUVs in PET/CT images, acquired with and without oral^{62, 63} and IV contrast^{64, 65}, have been reported. The authors have concluded that, when contrast agents were used, good vascular and intestinal enhancement was possible without compromising FDG PET quality^{64, 65} or inducing clinically significant artifacts⁶³. However, high concentrations of these agents (e.g., vena cava on bolus injection) can result in attenuation correction-based artifacts leading to over-estimations of regional FDG concentrations, therefore delays are generally employed between contrast injection and start of CT imaging (e.g., 40 seconds)⁶⁶.

The work of Berthelsen, et al.⁶⁶ prospectively addressed the significant issues surrounding the use of iodinated contrast agents in PET/CT by performing CT imaging for attenuation correction both with and without contrast. With contrast present, the global activity, and therefore, global SUV, was increased with PET images based on CT with contrast present (4.5 ± 2.3%). In this sample, eight of

eleven tumors exhibited an increased SUV_{max} ($2.9 \pm 3.1\%$). However, no contrast-induced artifacts were observed and the clinical interpretations between the two sets of images had weighted kappa values of 0.92 and 0.82 for the two specialists, respectively. Although the general clinical interpretations were not altered significantly, the authors pointed out that when the SUV will be used in a quantitative fashion, such as in therapeutic monitoring, changes in tumor vascularity will alter the volume of contrast agent present in the tumor. Their recommendation was to limit PET/CT imaging for treatment response evaluation (i.e., before and after treatment) to scans employing CT without contrast enhancement for attenuation correction only. Therefore, the benefits of only one diagnostic CT exam (e.g., lower radiation exposure, convenience to patient, more reliable co-registration of the contrast-enhanced images) entail only minor costs in the PET interpretability that can generally be easily factored into the clinical decision.

The use of iodinated contrast media in PET imaging introduces another dimension to professional practice demands in the PET Center, that is, the potential for severe and potentially life-threatening adverse reactions. Patients should be screened using the institution's instruments for determining eligibility and risks associated with contrast media. Screening should include history of allergy to iodinated contrast material, use of metformin, and renal disease. IV contrast should not be administered if the serum creatinine level is above 2 mg per dL¹³. Because of the risk of functional oliguria with IV contrast media and the risk of lactic acidosis with metformin, the metformin should be discontinued at the time of the contrast-enhanced study. Doses should be withheld for 48 hours after the procedure and not restarted until after documentation of resumption of adequate renal function⁶⁷. Imaging facilities should have the equipment necessary and personnel trained to treat contrast reactions.

Furosemide - Excreted FDG present in the urinary tract can present significant problems in the assessment of the pelvic area for pathological uptake. The use of OSEM reconstruction techniques over filtered back-projection and imaging at later times, have reduced but not eliminated this problem. When evaluation of the pelvic area is critical, bladder irrigation with or without the administration of a diuretic may be needed. As mentioned earlier, the urinary (Foley) catheter should be placed prior to the FDG administration. With a catheter, the risk of urinary urgency during imaging is eliminated, therefore, hydration, whether oral or intravenous, can be significantly increased. For example, 1000 mL of normal saline can be administered during the uptake time unless the patient is on fluid restriction. The diuretic of choice is IV furosemide due to its rapid and short-lived diuretic activity.

The onset of action is approximately 5 minutes, with peak action within 30 minutes and duration of two hours⁶⁸. The usual dosage is 20 mg but may be increased to 40 mg in patients with reduced renal function. The furosemide dose should be administered approximately 30 minutes prior to the start of imaging in order to “flush” the urinary tract of activity immediately before imaging. The dose should not be administered until at least 10 – 15 minutes after the administration of the FDG in order to avoid enhancing the excretion of the tracer due to increases in glomerular filtration. A recent publication⁶⁹ has documented the improvement in the detection of abdominopelvic malignancies with the use of IV furosemide coupled with IV (500 mL saline) and oral hydration (400 mL water) without an urgent need to void during the relatively short imaging times needed with the new scanners (e.g., 14 – 21 minutes for PET only and 9 – 13 minutes for PET/CT).

Drug Interactions

Laxatives - Early in the use of FDG for whole body imaging, authors advocated the use of bowel cleansing regimens prior to the procedure in order to reduce the amount of FDG in the gut. This recommendation was based on the erroneous assumption that FDG was excreted into the lumen of the bowel and that this would not be the case if the bowel were cleansed of fecal material. However, uptake in the gut area is does not result from FDG excretion into the lumen but rather from FDG accumulation in the musculature of the gut wall. The use of a laxative that stimulates peristalsis and may produce irritation of the tissues runs the risk of increasing FDG uptake rather than reducing it, posing a potential interference with abdominal imaging¹.

Colony-Stimulating Factor - To counteract the myelosuppressive effects of cancer chemotherapy agents, colony growth stimulators, such as filgrastim and pegfilgrastim, are frequently prescribed to patients with non-myeloid malignancies. These agents act on hematopoietic cells to stimulate proliferation, differentiation, and end-cell functional activation⁷⁰. This augmentation of hematopoietic function increases the metabolism of the spleen and bone marrow, and therefore, the uptake of FDG into these tissues^{70, 71}. The increased uptake into these tissues causes two concerns that must be considered during image interpretation. First, the alterations in biodistribution may result in the reduced availability of FDG to other tissues including tumors. In the monitoring of therapeutic response, reduced tumor uptake may stem from reduced FDG availability rather than tumor response when significant alterations in biodistribution occur. Secondly, the enhanced uptake into the spleen and bone marrow, which may be very intense in some patients, has the potential to mask malignant disease, especially metastases to the bone marrow itself. Increased marrow uptake generally returns to

pre-treatment levels by approximately one month after discontinuing colony stimulating factors⁷². The use of these agents should be considered in the scheduling and interpretation of FDG studies.

Corticosteroids - Corticosteroids are frequently used in combination with antineoplastic agents in the treatment of cancer (e.g., CHOP (cyclophosphamide, doxorubicin, vincristine (oncovin), prednisone for lymphoma and MOPP (mechlorethamine, vincristine, procarbazine, prednisone)) and for a multitude of other uses such as in allergic (e.g., anaphylaxis, edema, rhinitis), collagen (e.g., lupus), dermatologic (e.g., dermatitis), endocrine (e.g., adrenocortical insufficiency), gastrointestinal (e.g., ulcerative colitis, Crohn's disease), hematological (e.g., thrombocytopenia), neurological (e.g., multiple sclerosis), respiratory (e.g., asthma), and rheumatic (e.g., rheumatoid arthritis) disorders. The biological activity of glucocorticoids will increase blood glucose, by the following mechanisms, ultimately resulting in increased hepatic glycogen stores and insulin resistance:⁷³

- Stimulating gluconeogenesis
- Stimulating protein catabolism (substrates for gluconeogenesis)
- Decreasing peripheral utilization of glucose
- Increasing lipolysis and mobilizing fatty acids from adipose tissues

Two reports characterize the risk of hyperglycemia from corticosteroids in hospitalized patients. Hailemeskel, et al⁷⁴ found 11 of 20 patients with corticosteroid-induced adverse reactions experienced hyperglycemia. Of these patients, the average increase in blood glucose level was 240 mg/dL (range = 95 - 701 mg/dL). Only three of these patients had pre-existing diabetes, yet required the initiation of insulin therapy. Mathis, et al.⁷⁵ found 14.9% of adverse drug reactions at their institution were associated with corticosteroids and that of these 75.8% were hyperglycemia. History of recent corticosteroid use, even in non-diabetic patients, should signal the potential for hyperglycemia and insulin resistance, and the need for special management to ensure an appropriate blood glucose level at the time of scanning.

Other agents that pose a risk for Hyperglycemia - Any drug or therapy that alters or may alter blood glucose and/or insulin levels poses the risk for "pharmacological" interactions with FDG. Drugs used to treat diabetes will obviously be included in considerations of potential effects on FDG biodistribution. Risks of hypoglycemia or hyperglycemia occur with other classes of drugs that may not be immediately considered. Two examples are atypical antipsychotic agents and fluoroquinolones. Patients treated with atypical antipsychotics, especially clozapine and olanzapine, exhibit an increased risk of insulin resistance even if not obese⁷⁶ and have a significantly higher risk of developing diabetes⁷⁷. Fluoroquinolones have been associated with both hypoglycemia and hyperglycemia⁷⁸ with

the incidence of both adverse effects being relatively rare. Hyperglycemia may occur in 1.0 to 3.3% of treated patients depending on age (1.0% for < 65 years, 1.6% for 65 – 79 years, 3.3% for > 80 years, respectively). There have been reports of profound increases in blood glucose levels in a patient (57 year old male) treated for cellulitis with gatifloxacin⁷⁹ (blood glucose level as high as 992 mg per dL). These two examples highlight both the need to know all medications that a patient is currently on as well as the need to always measure blood glucose levels prior to a PET study.

Pharmaceutical Care Roles

What pharmaceutical care roles, as posed in Figure 1, can be defined for each of the practice settings?

Institutionally-based Nuclear Pharmacist - Institutionally-based nuclear pharmacists need to not only provide dispensing services for radiopharmaceuticals but also be a source of drug information and consultation on practice-related issues. The development of policies regarding breast-feeding in women needing nuclear medicine imaging is an opportunity for nuclear pharmacists to serve not only the patient but to educate medical personnel in rational restrictions based on pharmacokinetics. The amount of FDG excreted in the milk is a relatively minor radiation risk, falling below the 1 mSv recommended limit to infants. However, the potential intense uptake of FDG in the lactating breast poses a greater risk from radiation exposure from close contact during feeding. So, in this case, the milk is “safe” but should be expressed and fed to the infant by a third party, during the relatively short period of time that the mother is “radioactive”.

Centralized Nuclear Pharmacist - The centralized nuclear pharmacist should stress to the hospital that there is a need for a consistent and controlled environment for FDG uptake. Blood glucose monitoring equipment must be available. The patient should not be ambulating during the uptake phase, especially not outside during inclement weather. FDG is not a “one-size-fits-all” type of approach. Brain, heart and tumor studies all have very different study requirements for high quality and diagnostic images to be acquired.

Hospital Pharmacist - Hospital pharmacists need to understand that blood glucose and insulin levels will affect FDG studies. Dextrose-based intravenous solutions and parenteral nutrition must be discontinued four to six hours prior to the FDG PET study. For TPNs, a gradual resumption after the study is advised.

Community Pharmacist - Community pharmacists need to understand that FDG is a glucose analogue and therefore, even though this may be a brain, heart or cancer imaging study, blood glucose levels will affect the outcome of the examination.

All Pharmacists - All pharmacists can play an important role in ensuring optimal FDG PET imaging results – that role is to be actively involved in assuring that their patient’s blood glucose levels are carefully monitored and controlled when necessary.

CONCLUSION

The mechanistically simple and broad utility of FDG PET imaging belies the complexities of optimizing this diagnostic agent. It has been the purpose of this lesson to provide the reader with an understanding of the factors that alter glucose metabolism throughout the body, therefore, FDG distribution, and the technical rigors necessary to successfully image this radiopharmaceutical.

APPENDIX A

Pharmacokinetic Models for the Determination of the Metabolic Rate of Glucose from FDG Images

The compartmentally-based pharmacokinetic model is represented mathematically by the following equations²¹:

$$C_e^*(t) = \frac{K_1^*}{\alpha_2 - \alpha_1} \left[(k_4^* - \alpha_1) e^{-\alpha_1 t} + (\alpha_2 - k_4^*) e^{-\alpha_2 t} \right] \otimes C_p^*(t) \quad [1]$$

$$C_m^*(t) = \frac{K_1^* k_3^*}{\alpha_2 - \alpha_1} (e^{-\alpha_1 t} - e^{-\alpha_2 t}) \otimes C_p^*(t) \quad [2]$$

$$C_T^*(t) = \frac{K_1^*}{\alpha_2 - \alpha_1} \left[(k_3^* + k_4^* - \alpha_1) e^{-\alpha_1 t} + (\alpha_2 - k_3^* - k_4^*) e^{-\alpha_2 t} \right] \otimes C_p^*(t) \quad [3]$$

where

$$\alpha_1 = \frac{(k_2 + k_3 + k_4) - \sqrt{(k_2 + k_3 + k_4)^2 - 4k_2 k_4}}{2} \quad [4]$$

$$\alpha_2 = \frac{(k_2 + k_3 + k_4) + \sqrt{(k_2 + k_3 + k_4)^2 - 4k_2 k_4}}{2} \quad [5]$$

The metabolic rate of glucose utilization (MRglc) is defined as

$$MRglc = \left(\frac{K_1^* k_3^*}{k_2^* + k_3^*} \right) \frac{C_p}{LC} = K^* \frac{C_p}{LC} \quad [6]$$

where C_p is the blood glucose concentration and LC is the tissue-specific lumped constant, a factor which relates the kinetic behavior of FDG to the behavior of glucose.

The above modeling approach requires dynamic imaging, characterization of the arterial input function and compartmental modeling, a technically demanding analysis procedure. Alternative approaches are available to determine the metabolic rate of glucose, MRglc, specifically, by using population-based microparameters (i.e., K_1^* , k_2^* - k_4^*) and a single static image and by the determination of the macroparameter, K^* , via the Patlak plot.

With a single static image, arterial plasma concentrations determined from time = 0 to end of image, and population-based values for the microparameters, the following equation can be used for the determination of the metabolic rate of glucose.

[7]

$$MRglu = \frac{\frac{C_p}{LC} \left\{ C_T^*(T) - \frac{K_1^*}{\alpha_2 - \alpha_1} \left[(k_4^* - \alpha_1) e^{-\alpha_1 t} + (\alpha_2 - k_4^*) e^{-\alpha_2 t} \right] \right\} \otimes C_p^*(t)}{\frac{k_2^* + k_3^*}{\alpha_2 - \alpha_1} (e^{-\alpha_1 t} - e^{-\alpha_2 t}) \otimes C_p^*(t)}$$

In Patlak analysis^{21, 23}, after some time $t > t^*$, a plot of the normalized tissue activity (y-axis) versus the normalized time (x-axis) yields a linear relationship with a slope equivalent to the macroparameter, K^* . The normalized tissue activity is equivalent to the tissue concentration at time = t divided by the plasma activity at that same time (units = none) and the normalized time is the area-under-the-curve of the plasma activity at a particular time divided by the plasma activity at that same time (units = time)

$$\frac{C_T^*(t)}{C_p^*(t)} \text{ (y axis) versus } \frac{\int_0^t C_p^*(s) ds}{C_p^*(t)} \text{ (x axis)}$$

REFERENCES

1. Radiopharmaceuticals UECo. Fludeoxyglucose F 18 (Systemic). *USP-DI : Drug Information for the Health Care Professional*. Vol I. Greenwood Village, Colorado: Thomson MICROMEDEX; 2003:electronic monograph.
2. Medina RA, Owen GI. Glucose Transporters: Expression, Regulation and Cancer. *Biological Research*. 2002;35:9-26.
3. Joost H-G, Thorens B. The extended GLUT-family of sugar/polyol transport facilitators: nomenclature, sequence characteristics, and potential function of its novel members. *Molecular Membrane Biology*. 2001;18(4):247-256.
4. Macheda ML, Rogers S, Best JD. Molecular and cellular regulation of glucose transporter (GLUT) proteins in cancer. *Journal of Cellular Physiology*. 2005;202(3):654-662.
5. Mochizuki T, Tsukamoto E, Kuge Y, et al. FDG Uptake and Glucose Transporter Subtype Expressions in Experimental Tumor and Inflammation Models. *J Nucl Med*. October 1, 2001 2001;42(10):1551-1555.
6. Chung J-H, Cho K-J, Lee S-S, et al. Overexpression of Glut1 in Lymphoid Follicles Correlates with False-Positive 18F-FDG PET Results in Lung Cancer Staging. *J Nucl Med*. June 1, 2004 2004;45(6):999-1003.
7. Tateishi U, Yamaguchi U, Seki K, Terauchi T, Arai Y, Hasegawa T. Glut-1 expression and enhanced glucose metabolism are associated with tumour grade in bone and soft tissue sarcomas: a prospective evaluation by [¹⁸F]fluorodeoxyglucose positron emission tomography. *European Journal of Nuclear Medicine and Molecular Imaging*. 2006;33(6):683-691.
8. Higashi K, Ueda Y, Sakurai A, et al. Correlation of Glut-1 glucose transporter expression with [¹⁸F]FDG uptake in non-small cell lung cancer. *Eur J Nucl Med*. 2000;27(12):1778-1785.
9. Yen T-C, See L-C, Lai C-H, et al. 18F-FDG Uptake in Squamous Cell Carcinoma of the Cervix Is Correlated with Glucose Transporter 1 Expression. *J Nucl Med*. January 1, 2004 2004;45(1):22-29.
10. Miyakita H, Tokunaga M, Onda H, et al. Significance of 18F-fluorodeoxyglucose positron emission tomography (FDG-PET) for detection of renal cell carcinoma and immunohistochemical glucose transporter 1 (GLUT-1) expression in the cancer. *International Journal of Urology*. 2002;9(1):15-18.
11. Avril N. GLUT1 Expression in Tissue and 18F-FDG Uptake. *J Nucl Med*. June 1, 2004 2004;45(6):930-932.
12. Brown RS, Goodman TM, Zasadny KR, Greenson JK, Wahl RL. Expression of hexokinase II and Glut-1 in untreated human breast cancer. *Nuclear Medicine and Biology*. 2002;29(4):443-453.

13. Delbeke D, Coleman RE, Guiberteau MJ, et al. Procedure Guideline for Tumor Imaging with 18F-FDG PET/CT 1.0. *J Nucl Med*. May 1, 2006 2006;47(5):885-895.
14. Hays MT, Watson EE, Thomas SR, Stabin M. MIRDOSE Report No. 19: Radiation Absorbed Dose Estimates from ¹⁸F-FDG. *Journal of Nuclear Medicine*. 2002;43(2):210-214.
15. Hays MT, Watson EE, Thomas SR, Stabin M. MIRDOSE Report No. 19: Radiation Absorbed Dose Estimates from 18F-FDG. *J Nucl Med*. February 1, 2002 2002;43(2):210-214.
16. Wu T-H, Huang Y-H, Lee JJS, et al. Radiation exposure during transmission measurements: comparison between CT- and germanium-based techniques with a current PET scanner. *European Journal of Nuclear Medicine and Molecular Imaging*. 2004;31(1):38-43.
17. Brix G, Lechel U, Glatting G, et al. Radiation Exposure of Patients Undergoing Whole-Body Dual-Modality 18F-FDG PET/CT Examinations. *J Nucl Med*. April 1, 2005 2005;46(4):608-613.
18. Russell JR, Stabin MG, Sparks RB, Watson E. Radiation Absorbed Dose to the Embryo/Fetus From Radiopharmaceuticals. *Health Physics*. 1997;73(5):756-769.
19. Hicks RJ, Binns D, Stabin MG. Pattern of Uptake and Excretion of 18F-FDG in the Lactating Breast. *J Nucl Med*. August 1, 2001 2001;42(8):1238-1242.
20. Hoekstra C, Paglianiti I, Hoekstra O, et al. Monitoring response to therapy in cancer using [18F]2-fluoro-2-deoxy-D-glucose and positron emission tomography: an overview of different analytical methods. *Eur J Nucl Med*. 2000 2000;27(6):731-743.
21. Gambhir SS. Quantitative Assay Development for PET. In: Phelps ME, ed. *PET: Molecular Imaging and Its Biological Applications*. New York: Springer-Verlag; 2004:125-216.
22. Patlak CS, Blasberg RG, Fenstermacher JD. Graphical Evaluation of Blood-to-Brain Transfer Constants from Multiple-Time Uptake Data. *Journal of Cerebral Blood Flow & Metabolism*. 1983;3:1-7.
23. Patlak CS, Blasberg RG. Graphical Evaluation of Blood-to-Brain Transfer Constants from Multiple-Time Uptake Data. Generalizations. *Journal of Cerebral Blood Flow & Metabolism*. 1985;5:584-590.
24. Graham MM, Peterson LM, Hayward RM. Comparison of Simplified Quantitative Analyses of FDG Uptake. *Nuclear Medicine & Biology*. 2000;27:647-655.
25. Zasadny K, Wahl R. Standardized uptake values of normal tissues at PET with 2-[fluorine-18]-fluoro-2-deoxy-D-glucose: Variations with body weight and a method for correction. *Radiology*. 1993 1993;189:847-850.
26. Stahl A, Ott K, Schwaiger M, Weber WA. Comparison of Different SUV-based Methods for Monitoring Cytotoxic Therapy with FDG PET. *European Journal of Nuclear Medicine and Molecular Imaging*. 2004;31(11):1471-1479.

27. Kim C, Gupta N, Chandramouli B, Alavi A. Standardized uptake values of FDG: Body surface area correction is preferable to body weight correction. *J Nucl Med.* 1994;35(1):164-167.
28. Keyes J. SUV: Standard uptake or silly useless value? *J Nucl Med.* 1995;36(10):1836-1839.
29. Shankar LK, Hoffman JM, Bacharach S, et al. Consensus Recommendations for the Use of 18F-FDG PET as an Indicator of Therapeutic Response in Patients in National Cancer Institute Trials. *J Nucl Med.* June 1, 2006;47(6):1059-1066.
30. Young H, Baum R, Cremerius U, et al. Measurement of clinical and subclinical tumour response using [18F]-fluorodeoxyglucose and positron emission tomography: review and 1999 EORTC recommendations. *European Journal of Cancer.* 1999;35(13):1773-1782.
31. Graham MM, Peterson LM, Hayward RM. Comparison of simplified quantitative analyses of FDG uptake. *Nuclear Medicine and Biology.* 2000;27(7):647-655.
32. Beaulieu S, Kinahan P, Tseng J, et al. SUV Varies with Time After Injection in 18F-FDG PET of Breast Cancer: Characterization and Method to Adjust for Time Differences. *J Nucl Med.* July 1, 2003;44(7):1044-1050.
33. Lindholm P, Minn H, Leskinen-Kallio S, Bergman J, Ruotsalainen U, Joensuu H. Influence of the blood glucose concentration on FDG uptake in cancer - A PET study. *J Nucl Med.* 1993;34(1):1-6.
34. Wong C-yO, Thie J, Parling-Lynch KJ, et al. Glucose-Normalized Standardized Uptake Value from 18F-FDG PET in Classifying Lymphomas. *J Nucl Med.* October 1, 2005;46(10):1659-1663.
35. Hallett WA, Marsden PK, Cronin BF, O'Doherty MJ. Effect of corrections for blood glucose and body size on [¹⁸F]FDG PET standardised uptake values in lung cancer. *Eur J Nucl Med.* 2001;28(7):919-922.
36. Pereira LO, Lancha JAH. Effect of insulin and contraction up on glucose transport in skeletal muscle. *Progress in Biophysics and Molecular Biology.* 2004;84(1):1-27.
37. Koistinen HA, Zierath JR. Regulation of glucose transport in human skeletal muscle. *Annals of Medicine.* 2002;34(6):410-418.
38. Akhurst T, Boland P, Macapinlac H, et al. Excess Muscle FDG Uptake in an Euglycaemic Patient That Is Corrected by Fasting. *Clinical Positron Imaging.* 1998;1(2):131-133.
39. Jaskowiak CJ, Bianco JA, Perlman SB, Fine JP. Influence of Reconstruction Iterations on 18F-FDG PET/CT Standardized Uptake Values. *J Nucl Med.* March 1, 2005;46(3):424-428.
40. Halpern BS, Dahlbom M, Auerbach MA, et al. Optimizing Imaging Protocols for Overweight and Obese Patients: A Lutetium Orthosilicate PET/CT Study. *J Nucl Med.* April 1, 2005;46(4):603-607.

41. Everaert H, Vanhove C, Lahoutte T, et al. Optimal dose of ^{18}F -FDG required for whole-body PET using an LSO PET camera. *Eur J Nucl Mol Imaging*. 2003;30(12):1615-1619.
42. Huang S, Carson R, Hoffman E, et al. Quantitative measurement of local cerebral blood flow in humans by positron computed tomography and ^{15}O -water. *J Cerebral Blood Flow Metab*. 1983 1983;3:141-153.
43. Anonymous. Insulin (Systemic). In: United States Pharmacopeial Convention I, ed. *USP-DI: Drug Information for the Health Care Professional*. 24 ed. Greenwood Village, Colorado: Thomson MICROMEDEX; 2004:1615-1629.
44. Swartz BE, Brown C, Mandelkern MA, et al. The Use of 2-Deoxy-2-[^{18}F]Fluoro- D-Glucose (FDG-PET) Positron Emission Tomography in the Routine Diagnosis of Epilepsy. *Molecular Imaging & Biology*. 2002;4(3):245-252.
45. Wong CY, Geller EB, Chen EQ, et al. Outcome of temporal lobe epilepsy surgery predicted by statistical parametric PET imaging. *J Nucl Med*. July 1, 1996 1996;37(7):1094-1100.
46. Leiderman D, Albert P, Balish M, Bromfield E, Theodore W. The dynamics of metabolic change following seizures as measured by positron emission tomography with fludeoxyglucose F 18. *Arch Neurol*. 1994 1994;51:932-936.
47. Kubota K, Itoh M, Ozaki K, et al. Advantage of delayed whole-body FDG-PET imaging for tumour detection. *Eur J Nucl Med*. 2001;28(6):696-703.
48. Matthies A, Hickeson M, Cuchiara A, Alavi A. Dual Time Point ^{18}F -FDG PET for the Evaluation of Pulmonary Nodules. *J Nucl Med*. July 1, 2002 2002;43(7):871-875.
49. Hustinx R, Smith RJ, Benard F, et al. Dual time point fluorine-18 fluorodeoxyglucose positron emission tomography: a potential method to differentiate malignancy from inflammation and normal tissue in the head and neck. 1999. 1999;26(10):1345-1348.
50. Jackson RS, Schlarman TC, Hubble WL, Osman MM. Prevalence and Patterns of Physiologic Muscle Uptake Detected with Whole-Body ^{18}F -FDG PET. *J Nucl Med Technol*. 2006;34(1):29-33.
51. Weber WA. Brown Adipose Tissue and Nuclear Medicine Imaging. *J Nucl Med*. 2004;45(7):1101-1102.
52. Hany T, Gharehpapagh E, Kamel E, Buck A, Himms-Hagen J, von Schulthess G. Brown adipose tissue: a factor to consider in symmetrical tracer uptake in the neck and upper chest region. *Eur J Nucl Med*. 2002 2002;29(10):1393-1398.
53. Yeung H, Grewal R, Gonen M, Schoder H, Larson S. Patterns of ^{18}F -FDG uptake in adipose tissue and muscle: A potential source of false-positives for PET. *J Nucl Med*. 2003 2003;44(11):1789-1796.
54. Cohade C, Osman M, Pannu H, Wahl R. Uptake in supraclavicular area fat ("USA-fat"): Description on ^{18}F -FDG PET/CT. *J Nucl Med*. 2003 2003;44(2):170-176.

55. Cohade C, Mourtzikos KA, Wahl RL. "USA-Fat": Prevalence is Related to Ambient Outdoor Temperature - Evaluation with ¹⁸F-FDG PET/CT. *J Nucl Med.* 2003;44(8):1267-1270.
56. Tatsumi M, Engles J, Cohade C, Wahl RL. FDG Accumulation in Brown Adipose Tissues Can Be Reduced Pharmacologically. *J Nucl Med.* 2003;44(5 Suppl):91P.
57. Tatsumi M, Engles JM, Ishimori T, Nicely OB, Cohade C, Wahl RL. Intense 18F-FDG Uptake in Brown Fat Can Be Reduced Pharmacologically. *J Nucl Med.* 2004;45(7):1189-1193.
58. Jacobsson H, Bruzelius M, Larsson SA. Reduction of FDG uptake in brown adipose tissue by propranolol. *Eur J Nucl Med Mol Imaging.* 2005;32(9):1130.
59. Anonymous. Benzodiazepines (Systemic). In: United States Pharmacopeial Convention I, ed. *USP-DI: Drug Information for the Health Care Professional.* 24 ed. Greenwood Village, Colorado: Thomson MICROMEDEX; 2004:518-540.
60. Anonymous. Midazolam (Systemic). In: United States Pharmacopeial Convention I, ed. *USP-DI: Drug Information for the Health Care Professional.* 24 ed. Greenwood Village, Colorado: Thomson MICROMEDEX; 2004:1961-1968.
61. Cohade C, Osman M, Nakamoto Y, et al. Initial Experience with Oral Contrast in PET/CT: Phantom and Clinical Studies. *J Nucl Med.* March 1, 2003 2003;44(3):412-416.
62. Antoch G, Kuehl H, Kanja J, et al. Dual-Modality PET/CT Scanning with Negative Oral Contrast Agent to Avoid Artifacts: Introduction and Evaluation. *Radiology.* March 1, 2004 2004;230(3):879-885.
63. Groves AM, Kayani I, Dickson JC, et al. Oral contrast medium in PET/CT: should you or shouldn't you? *Eur J Nucl Med Mol Imaging.* 2005;32(10):1160-1166.
64. Antoch G, Freudenberg LS, Stattaus J, et al. Whole-Body Positron Emission Tomography--CT: Optimized CT Using Oral and IV Contrast Materials. *Am. J. Roentgenol.* December 1, 2002 2002;179(6):1555-1560.
65. Yau Y-Y, Chan W-S, Tam Y-M, et al. Application of Intravenous Contrast in PET/CT: Does It Really Introduce Significant Attenuation Correction Error? *J Nucl Med.* February 1, 2005 2005;46(2):283-291.
66. Berthelsen AK, Holm S, Loft A, Klausen TL, Andersen F, Hojgaard L. PET/CT with intravenous contrast can be used for PET attenuation correction in cancer patients. *European Journal of Nuclear Medicine and Molecular Imaging.* 2005;32(10):1167-1175.
67. Anonymous. Metformin (Systemic). In: United States Pharmacopeial Convention I, ed. *USP-DI: Drug Information for the Health Care Professional.* 24 ed. Greenwood Village, Colorado: Thomson MICROMEDEX; 2004:1903-1908.

68. Anonymous. Diuretics, Loop (Systemic). In: United States Pharmacopeial Convention I, ed. *USP-DI: Drug Information for the Health Care Professional*. Vol 1. 24 ed. Greenwood Village, Colorado: Thomson MICROMEDEX; 2004:1135-1142.
69. Kamel EM, Jichlinski P, Prior JO, et al. Forced Diuresis Improves the Diagnostic Accuracy of 18F-FDG PET in Abdominopelvic Malignancies. *J Nucl Med*. November 1, 2006 2006;47(11):1803-1807.
70. Anonymous. Colony Stimulating Factors (Systemic). In: United States Pharmacopeial Convention I, ed. *USP-DI: Drug Information for the Health Care Professional*. Vol 1. 24 ed. Greenwood Village, Colorado: Thomson MICROMEDEX; 2004:880-886.
71. Jacene HA, Ishimori T, Engles JM, Leboulleux S, Stearns V, Wahl RL. Effects of Pegfilgrastim on Normal Biodistribution of 18F-FDG: Preclinical and Clinical Studies. *J Nucl Med*. June 1, 2006 2006;47(6):950-956.
72. Kazama T, Swanston N, Podoloff DA, Macapinlac HA. Effect of colony-stimulating factor and conventional- or high-dose chemotherapy on FDG uptake in bone marrow. *Eur J Nucl Mol Imaging*. 2005;32(12):1406-1411.
73. Anonymous. Corticosteroids - Glucocorticoid (Systemic). In: United States Pharmacopeial Convention I, ed. *USP-DI: Drug Information for the Health Care Professional*. Vol 1. 24 ed. Greenwood Village, Colorado: Thomson MICROMEDEX; 2004:940-966.
74. Hailemeskel B, Dutta AP, Daftary MN, Olagbaju F, Ifelowo O. Corticosteroid-induced adverse reactions in a university teaching hospital. *Am J Health-Syst Pharm*. 2003;60(Jan 15, 2003):194-195.
75. Mathis AS, Liu MT. Corticosteroids an important cause of hyperglycemia. *Am J Health-Syst Pharm*. 2005;62(Oct 1, 2005):1976-1979.
76. Henderson DC, Cagliero E, Copeland PM, et al. Glucose Metabolism in Patients With Schizophrenia Treated With Atypical Antipsychotic Agents: A Frequently Sampled Intravenous Glucose Tolerance Test and Minimal Model Analysis. *Arch Gen Psychiatry*. January 1, 2005 2005;62(1):19-28.
77. Gianfrancesco F, Pesa J, Wang R-H, Nasrallah H. Assessment of antipsychotic-related risk of diabetes mellitus in a Medicaid psychosis population: Sensitivity to study design. *Am J Health-Syst Pharm*. 2006;63(Mar 1, 2006):431-441.
78. Owens RC. Fluoroquinolone-Associated Dysglycemias: A Tale of Two Toxicities. *Pharmacotherapy*. 2005;25(10):1291-1295.
79. Stading JA, Chock AWY, Skrabal MZ, Faulkner MA. Development of diabetes after gatifloxacin therapy. *Am J Health-Syst Pharm*. 2005;62(Nov 1, 2005):2293-2295.

QUESTIONS

1. The United States Approved Name (USAN) of FDG is:
 - A. Fluorodeoxyglucose F18 USP
 - B. Fludeoxyglucose F18 USP
 - C. Fluoroglucose F18 USP
 - D. Fluorodesoxyglucose F18 USP
 - E. Fluorodeglucose F18 USP

2. The purpose of the NOPR (National Oncologic Patient Registry) is:
 - A. To create a database of patients in the United States with cancer.
 - B. To track all patients with cancer who have had FDG PET studies.
 - C. To assess the utility of FDG oncologic imaging for indications beyond those currently reimbursed by Medicare/Medicaid for possible future reimbursement.
 - D. To assess potential long-term complications from FDG PET imaging in oncologic disease.
 - E. To revise the ICD9 codes for oncologic diseases.

3. The total radiation dose to the patient from a FDG PET study (10 mCi FDG) performed on a PET/CT compared to a PET-only scanner using Ge-68 based attenuation correction is:
 - A. Significantly higher.
 - B. Slightly higher.
 - C. Lower.
 - D. About the same.
 - E. No difference because the radiation dose is only from the FDG.

4. Administration of ^{18}F -FDG by mouth is:
 - A. A viable alternative in selected patients in which an IV line cannot be secured however limitations exist in the interpretation of the images.
 - B. A viable alternative in selected patients in which an IV line cannot be secured without limitations in the interpretation of the images.
 - C. Particularly useful in imaging patients with possible tumors of the GI tract.
 - D. Not a viable alternative because FDG is not absorbed orally.
 - E. None of the above.

5. FDG is not the optimal agent for the imaging of primary prostate cancer because:
- A. Prostate cancer tends to be a relatively slow-growing cancer and therefore not particularly metabolically active with respect to glucose.
 - B. The prostate gland is a relatively small organ.
 - C. The prostate gland lies close to the bladder which may be full of urine containing excreted FDG.
 - D. All of the above.
 - E. None of the above, FDG is an ideal agent for imaging primary prostate cancer.
6. Accurate standardized uptake values (SUV) require which of the following:
- A. Attenuation-corrected images.
 - B. Accurate measurement of the dosage actually administered to the patient.
 - C. Accurate measurement of the patient's weight.
 - D. Accurate measurement of the interval between dosage administration of start of imaging.
 - E. All of the above.
7. Tumors that are FDG-avid tend to have:
- A. Decreased levels of GLUT-1.
 - B. Increased levels of GLUT-1.
 - C. Decreased levels of GLUT-4.
 - D. Increased levels of GLUT-4.
 - E. No GLUT on their cell surfaces.
8. Tissues that are sensitive to the effects of insulin tend to have:
- A. Decreased levels of GLUT-1.
 - B. Increased levels of GLUT-1.
 - C. Decreased levels of GLUT-4.
 - D. Increased levels of GLUT-4.
 - E. No GLUT on their cell surfaces because insulin does not modulate the response of any glucose transporter proteins.
9. Optimal FDG uptake in tumors requires:
- A. Glucose levels in the normal, fasting state.
 - B. Endogenous or exogenous insulin.
 - C. Supplemental glucose administration.
 - D. All of the above.
 - E. None of the above.

10. Optimal FDG uptake in the heart requires:

- A. Glucose levels in the normal, fasting state.
- B. Endogenous or exogenous insulin.
- C. Supplemental fatty-acid administration.
- D. All of the above.
- E. None of the above.

11. Which of the following constitutes the major rationale for the use of FDG in brain imaging?

- A. Normal brain tissue utilizes a variety of substrates for energy but damaged brain tissue uses only glucose.
- B. Plaques and tangles present in Alzheimer's disease are highly FDG-avid.
- C. Because brain tissue utilizes glucose as an energy source nearly exclusively, the distribution of FDG in the brain reflects brain metabolism.
- D. Because of first-pass extraction, FDG uptake in the brain reflects brain blood flow.
- E. FDG specifically binds to cholinergic receptors present within the brain.

12. Oral or IV dextrose is administered to patients prior to FDG administration under which of the following circumstances?

- A. In brain imaging in order to ensure that the brain is utilizing glucose as its preferred fuel.
- B. In tumor imaging in order to ensure that there is adequate glucose present to facilitate FDG uptake.
- C. In cardiac imaging in order to ensure that there is adequate endogenous insulin present to facilitate cardiac glucose metabolism.
- D. Dextrose is administered prior to FDG in all cases.
- E. All of the above.

13. Benzodiazepines are used in oncologic FDG imaging:

- A. Because FDG has been known to precipitate anxiety attacks.
- B. To minimize BAT uptake of FDG.
- C. To facilitate relaxation in the uptake period in order to minimize skeletal muscle FDG uptake.
- D. To minimize FDG uptake in the brain.
- E. b and c above.

14. Nursing women should avoid breast-feeding their infants after receiving FDG:

- A. For at least a week.
- B. Because FDG is an antimetabolite and the infant may experience a toxic reaction to the FDG contained in the breast milk.
- C. Because FDG is metabolized to free fluoride ions that may cause mottling of developing teeth.
- D. Because of the potential radiation exposure to the infant from FDG excreted into the breast milk but more importantly from the close proximity of the infant to the mother during nursing.
- E. All of the above.

15. Which of the following statements Laxatives:

- A. Should be used the day prior to imaging for bowel cleansing in order to minimize the gut uptake of FDG.
- B. Should be used prior to imaging to remove any FDG excreted into the feces which could interfere with image interpretation.
- C. Should be used after FDG imaging to remove any FDG excreted into the feces that could add to the radiation exposure of the GI tract.
- D. Should not be used prior to FDG administration because laxatives will interfere with glucose absorption from the GI tract.
- E. Should not be used prior to FDG administration because the stimulatory action may increase intestinal muscle uptake of FDG.

16. In patients with possible lung cancer,

- A. Coughing should be encouraged during the FDG uptake phase in order to remove FDG in the secretions prior to imaging.
- B. Coughing should be minimized during the FDG uptake phase due to exertion-based increases in FDG uptake in chest, neck and abdominal muscles.
- C. Coughing should be suppressed with cough drops or cough syrups containing sugar.
- D. Coughing will not influence FDG uptake.
- E. b and c above.

17. In FDG imaging of epileptic patients, the seizure foci

- A. Are hypermetabolic interictally but hypometabolic ictally.
- B. Are hypometabolic interictally but hypermetabolic ictally.
- C. Are always hypometabolic irrespective of seizure status.
- D. Are always hypermetabolic irrespective of seizure status.
- E. Are not identifiable.

18. Which of the following cancer therapies/adjunctive treatments will influence the biodistribution of FDG?

- A. Colony stimulating factors.
- B. Chemotherapy.
- C. Radiation therapy.
- D. Surgery.
- E. All of the above.

19. Which of the following is true for patients with oncologic disease and diabetes?

- A. Patients with Type II diabetes cannot be imaged with FDG because insulin resistance impedes FDG uptake into tumors.
- B. Patients with Type I diabetes cannot be imaged with FDG because exogenous insulin interferes with FDG uptake into tumors.
- C. The patient's insulin dose should be administered immediately before the FDG administration in order to lower blood glucose levels.
- D. Patients with diabetes should eat immediately before FDG administration in order to ensure that the patient does not become hypoglycemic.
- E. Diabetic patients should work with their physician and the PET Center staff to ensure that their blood glucose levels are within the normal, fasting range without high levels of insulin at the time of FDG administration.

20. The biodistribution of FDG and glucose differ in which of the following ways?

- A. Glucose uptake into cells is facilitated by glucose transporter proteins whereas FDG uptake is not.
- B. Glucose is phosphorylated by hexokinase whereas FDG is not phosphorylated.
- C. Filtered glucose is essentially completely reabsorbed whereas FDG is excreted unchanged in the urine.
- D. Glucose is metabolized via the TCA cycle to CO_2 and H_2O whereas FDG is metabolized via the TCA cycle to CO_2 , H_2O and F^- .
- E. Glucose is metabolized whereas FDG undergoes no metabolic alterations.

21. Which of the following may be a cause of false positive results on whole body imaging for oncologic disease?

- A. Tuberculosis
- B. Hyperglycemia
- C. Small tumor size
- D. Osteoblastic skeletal metastases
- E. Tumor necrosis

22. Which of the following may be a cause of false negative results on whole body imaging for oncologic disease?

- A. Injection site
- B. Well differentiated tumors
- C. Osteomyelitis
- D. Esophagitis
- E. Hypoglycemia

23. Measures that can be used to minimize uptake of FDG into BAT include:

- A. Beta-blockers
- B. Benzodiazepines
- C. Warm blankets
- D. Relaxed environment
- E. All of the above

24. Adjunctive furosemide is used in FDG imaging to:

- A. Augment FDG uptake into the myocardium in patients with congestive heart failure.
- B. Reduce the radiation exposure to the brain by increasing FDG excretion.
- C. Induce impaired glucose tolerance and create a functional hyperglycemia.
- D. "Flush" the urinary tract of FDG present in the urine in order to improve visualization of the pelvic area.
- E. Block the excretion of FDG into the urine.

25. Which of the following statements is true?

- A. Recent chemo- and/or radiotherapy does not factor into the decision as to when a patient should be imaged with FDG.
- B. Recent chemo- and/or radiotherapy is a contraindication to FDG imaging.
- C. Recent chemo- and/or radiotherapy may cause false positive scans due to inflammatory responses and false negative scans due to tumor "stunning".
- D. Recent chemotherapy but not radiotherapy may cause false positive, but not false negative scans.
- E. Recent chemo- and/or radiotherapy is not an issue because FDG is only used as a diagnostic agent pre-therapy in oncologic disease.